

(19) World Intellectual Property Organization
International Bureau



(43) International Publication Date
1 August 2002 (01.08.2002)

PCT

(10) International Publication Number
WO 02/058847 A2

- (51) International Patent Classification⁷: **B01L 3/00**
- (21) International Application Number: PCT/US01/44289
- (22) International Filing Date:
28 November 2001 (28.11.2001)
- (25) Filing Language: English
- (26) Publication Language: English
- (30) Priority Data:
60/253,094 28 November 2000 (28.11.2000) US
- (71) Applicant (for all designated States except US):
GEORGETOWN UNIVERSITY [US/US]; 3900
Reservoir Road, N.W., Washington, DC 20007 (US).
- (72) Inventors; and
(75) Inventors/Applicants (for US only): **PARANJAPE, Makarand** [CA/US]; 1530 N. Key Boulevard, Apt. 503, Arlington, VA 22209 (US). **ESRICK, Mark, A.** [US/US]; 2400 41st Street, N.W. Apt. #508, Washington, DC 20007 (US). **CURRIE, John, F.** [CA/US]; 6523 Fallwind Lane, Bethesda, MD 20817 (US).
- (74) Agents: **TESKIN, Robin, L.** et al.; Pillsbury Winthrop LLP, 1600 Tysons Boulevard, McLean, VA 22102 (US).
- (81) Designated States (national): AE, AG, AL, AM, AT, AU, AZ, BA, BB, BG, BR, BY, BZ, CA, CH, CN, CO, CR, CU, CZ, DE, DK, DM, DZ, EC, EE, ES, FI, GB, GD, GE, GH, GM, HR, HU, ID, IL, IN, IS, JP, KE, KG, KP, KR, KZ, LC, LK, LR, LS, LT, LU, LV, MA, MD, MG, MK, MN, MW, MX, MZ, NO, NZ, OM, PH, PL, PT, RO, RU, SD, SE, SG, SI, SK, SL, TJ, TM, TR, TT, TZ, UA, UG, US, UZ, VN, YU, ZA, ZM, ZW.
- (84) Designated States (regional): ARIPO patent (GH, GM, KE, LS, MW, MZ, SD, SL, SZ, TZ, UG, ZM, ZW), Eurasian patent (AM, AZ, BY, KG, KZ, MD, RU, TJ, TM), European patent (AT, BE, CH, CY, DE, DK, ES, FI, FR, GB, GR, IE, IT, LU, MC, NL, PT, SE, TR), OAPI patent (BF, BJ, CF, CG, CI, CM, GA, GN, GQ, GW, ML, MR, NE, SN, TD, TG).

Published:

— without international search report and to be republished upon receipt of that report

For two-letter codes and other abbreviations, refer to the "Guidance Notes on Codes and Abbreviations" appearing at the beginning of each regular issue of the PCT Gazette.



WO 02/058847 A2

(54) Title: CELL TRANSFORMATION USING A SINGLE CHIP SILICON MICROFABRICATED ARRAY INCORPORATING INTEGRATED MICRO-PIERCING INJECTORS

(57) Abstract: The present invention provides an improved methodology for the introduction of specific molecules into cells, or the removal of material from cells, over the current state of the art. In particular, the invention provides an efficient means for these procedures to be undertaken on a high throughput level using minimally skilled expertise and handling by providing a microfabricated silicon array substrate having a simplified device fabrication strategy, whereby a single device component performs the transformation process rendering a more durable and robust device.

**Cell Transformation Using a Single Chip Silicon Microfabricated Array
Incorporating Integrated Micro-Piercing Injectors**

[0000] This application claims the benefit of U.S. Provisional Application No. 60/253,094, filed on November 28, 2000, the entire contents of which are incorporated herein by reference thereto.

Field of Invention

[0001] This invention relates to methods for transforming or transfecting a plurality of individual cells with nucleic acids, small drug doses or other molecules of interest, and particularly to microfabricated devices for performing such transformations and other minute operations on a high throughput level.

Background of Invention

[0002] Cell transformation is a procedure often used by researchers in genetics, cell biology, and molecular biology that results from the introduction of specific molecules, such as DNA, RNA, and low-dose drugs into the nucleus or cytoplasm of a recipient cell. Transformation allows for the identification of novel genes, the isolation of genetically modified cells, and the screening of potential drugs, and much effort has been focused on ensuring that transformation efficiencies are optimized in order to increase the retrieval of transformed cells and/or decrease the number of cells which must be treated.

[0003] Technologies associated with improving transformation efficiency and cell viability following transformation have seen extensive research and development. For instance, classical methods include chemical means whereby cells are treated with either calcium phosphate/DNA or DEAE-DeXtran/DNA in order to integrate an isolated gene into the nuclear genome (transfection) of mammalian cells. Although calcium phosphate transformation is relatively inexpensive and can accommodate high concentrations of DNA, transfection efficiency is often less than 10% and is typically associated with a low rate of viability. Likewise, while DEAE-DeXtran is advantageous in that it typically requires less DNA than other methods and is applicable to many different types of cells, it also suffers from low transfection efficiency and high toxicity.

[0004] Biological means of transforming cells have also been developed. For instance, replication-deficient recombinant retroviruses may be used to accurately integrate a

single copy of a gene into the genome of a target cell. However, such vectors cannot infect non-dividing or fully differentiated cells, e.g., neurons or hepatic cells, unless they are stimulated to divide, and can only accommodate genes and other nucleic acids that are less than 8 kilobases long. Furthermore, purification and concentration of retroviruses without loss of infectivity is difficult, and stable transfectants which exhibit long-term expression of transfected genes are rare. Recombinant adenoviruses are advantageous in that they infect non-dividing cells and may be concentrated without significant loss of infectivity. However, these viruses can only incorporate genes which are less than 5 kilobases, and their genome does not integrate into the target cell's genome but rather remains episomal, resulting in transient gene expression.

[0005] Physical methods of transformation have also been developed. Electroporation employs an electric pulse applied to a cell/DNA suspension, and is believed to induce local areas of reversible membrane breakdown thereby creating pores through which the DNA enters the cell. Although electroporation is effective for a large number of different cell types and is relatively reproducible and easy to perform, it requires more cells and DNA than chemical methods and there is typically a large variation in optimizing parameters between different cell lines, e.g., field strength, pulse duration. Moreover, efficiency may vary depending on the cell type, and the non-physiological conditions required in the medium limit cell viability.

[0006] Particle bombardment has also been used, whereby DNA coated tungsten or gold particles are accelerated into cells. However, this technique usually yields only transient gene expression. Liposomal delivery provides the advantages of higher efficiency and relatively low cell toxicity, and is amenable to the transformation of more molecules than just DNA, including RNA, synthetic oligonucleotides, proteins and viruses. However, liposomes are relatively costly, practically precluding their use for large scale transfections. Microinjection using a fine tipped pipet may also be used to introduce DNA, RNA, antibodies, peptides and oligonucleotides into cells, and has proved successful with large frog eggs, mammalian embryos, plant protoplasts and tissues. However, this technique

is extremely labor intensive in that only one cell is injected at a time. See Nikitin et al, U.S. Patent 4,619,899.

[0007] More recently, silicon-based micromachined systems have been developed which eliminate some of the problems associated with the above methods. For instance, electroporation may now be performed on the micro-level whereby cells are trapped in microchambers fitted with electrodes, electroporated, and exogenous genetic material is diffused through the resultant pores into the cells. While there is the potential that all cells can be transfected since all are treated identically, the amount of exogenous material that enters the cells can not be controlled. Furthermore, device fabrication is not straightforward. See Le Pioufle et al, Attachment of Cells on Microsystems: Application to the Gene Transfection, Transducers '99, 768-71, Sendai, Japan.

[0008] Hollow micro-capillaries have also been designed which permit controlled injection of DNA and other materials into cells, whereby the hollow micro-capillaries are inserted into individual cells trapped in microchambers within the surface of a silicon wafer and the material of interest is injected. See McAllister et al, Three-Dimensional Hollow Micro-Needle and Micro-Tube Arrays, Transducers '99, 1098-1101, Sendai, Japan; see also Chun et al, An Array of Hollow Microcapillaries for the Controlled Injection of Genetic Materials into Animal/Plant Cells, 12th IEEE Int'l Conf. on Microelectromechanical Systems, Orlando, Fl, Jan. 1999, pp. 406-411. Microprobes or short points covered with genetic material have also been used to pierce cells and introduce the genetic material into an array of individual cells. Although such microfabricated devices are advantageous in the control they provide over transfection conditions, the ease of operation, and the level of transfection efficiency achieved, the apparatus requires two separate devices (micro-capillary array for injection and micro-chamber array for holding the cells). Such a system inherently possesses critical alignment problems resulting in variations in injection efficiency, and typically requires a further device for positioning the first two devices accurately with respect to one another. See Leighton and Brownstein, U.S. Patent 5,262,128. Moreover, the micro-capillary needles are fragile and therefore not very durable, and require a complex and specialized fabrication process.

[0009] Thus, there is a need for cell transformation systems which result in high efficiency, e.g., high throughput, and low cell death, and which avoid the high cost and labor intensive expenditures seen in the prior art. Further, in terms of microdevices, more durable designs are needed which do not require complicated fabrication processes.

Summary of Invention

[0010] The present invention overcomes the deficiencies of the prior art by providing a cost effective, durable apparatus that enables essentially simultaneous transformation (into the cytoplasm) or transfection (into the nucleus) of a plurality of cells with a wide variety of molecules and substances. More particularly, the present invention provides a silicon wafer containing an array of micro-cavities fitted with hollow needle like protrusions allowing individual cells to be simultaneously trapped and pierced for material injection or extraction.

[0011] The micro-device of the present invention is advantageous over devices of the prior art in that a large number of cells may be easily transformed or transfected in a single step with minimal loss of cell viability, requiring minimal expertise and handling at an optimum cost. In particular, because the microdevices of the present integrate micro-piercing injectors into the design of the micro-chambers, the present devices are simpler to make, e.g., are made using standard silicon processing and micromachining technologies, and are more durable than the silicon chip injection units of the prior art. Further, the micro-devices of the present invention are one-piece injection modules that require no critical alignment procedures.

[0012] Also included in the invention are methods of transforming and transfecting a plurality of cells with a variety of molecules and substances using the microdevices of the present invention, and also methods of fusing different types of cells using the disclosed devices. Cell transformation, transfection and fusion may be performed in a parallel process with the potential for high throughput using multi-level stacked elements. Transformed and transfected cells produced by the methods of the invention are also included, as are a variety of supplementary devices and connections which facilitate collection and analyses of the transformed cells.

Brief Description of the Figures

- [0013]** Figure 1. Diagram of a preferred cell transformation microdevice of the present invention.
- [0014]** Figure 2. Enlarged view of a single micro-piercing injector.
- [0015]** Figure 3. Cross-sectional view of cavity formation using a masking layer with an isotropic etchant.
- [0016]** Figure 4. Top and cross-sectional view of the annulus masking pattern.
- [0017]** Figure 5. Cross-sectional views of the etch profile of isotropic etching for varying times.
- [0018]** Figure 6. Cross-sectional view of the micro-injector with inlet port.
- [0019]** Figure 7. Fabrication process flow for (a) ultra-thin wafer, and (b) SOI wafer. The only difference in the fabrication sequence shown above is in the first step where front-side lithography is done on the SOI wafer, while back-side lithography on the ultra-thin wafer.
- [0020]** Figure 8. An SEM of the test structure for determining RIE isotropy.
- [0021]** Figure 9. An SEM of the annuli test structure.
- [0022]** Figure 10. SEM of one annulus test structure.
- [0023]** Figure 11. SEM of an annulus test structure of different dimension.
- [0024]** Figure 12. Surface topography scans for the annuli of (a) Fig. 10 and (b) Fig. 11.
- [0025]** Figure 13. Results of trial at 95/0 W with varied percentage O₂ (a) RIE etch rate; (b) Si/SiO₂ selectivity; and (c) Silicon etch anisotropy.
- [0026]** Figure 14. SEM's illustrating the anisotropy and etch profiles for the trial of Figure 13 using (a) 10% O₂ and (b) 20% O₂.
- [0027]** Figure 15. Results of trial at 205/5 W with varied percentage O₂ (a) RIE etch rate; (b) Si/SiO₂ selectivity; and (c) Silicon etch anisotropy.
- [0028]** Figure 16. Results of trial at 95/0 W with percentage O₂ fixed at 10% (a) RIE etch rate; (b) Si/SiO₂ selectivity; and (c) Silicon etch anisotropy.
- [0029]** Figure 17. Plexiglass, water tight CTM macro-model for pressure analysis used in conjunction with one embodiment of the invention.

[0030] Figure 18. Cross-section of micro-injector with inlet and venting ports in accordance with a preferred embodiment of the invention.

[0031] Figure 19. Device according to a preferred embodiment of the invention using polydimethylsiloxane silicone rubber (PDMS).

[0032] Figure 20. SEM's of (a) SU-8 mold and (b) PDMS layer made therefrom.

Detailed Description of the Invention

[0033] In one aspect, the present invention encompasses microfabricated array/injection devices for transforming simultaneously a plurality of cells. A preferred microdevice structure is based on a single chip module containing a large array of microchambers or micro-wells in a silica-based or silicon substrate that house recipient cells to be transformed (Fig. 1). Inlet ports located at the bottom of each microchamber are integrated into the device in such a way as to simultaneously render micro-piercing injectors during micro-chamber fabrication (Fig. 2). The silicon structure is bonded with a capping substrate on the top in order to introduce recipient cells into the micro-chambers and hold them in place, preferably by the application of hydrostatic pressure, and also with a bottom substrate that contains micro-fluidic channels for biological and molecular component transport (Fig. 1).

[0034] Initially, the cells are allowed to settle into the bottom of each micro-chamber, and when all cavities are filled, hydrostatic pressure is applied from above to trap and hold them in place. During the entrapment procedure, the cell membrane is perforated mechanically by the micro-piercing structures. The inlet ports act as micro-injectors through which biological material or molecules are introduced into the cell using positive pressure applied beneath the micro-injector array. This pressure is applied shortly after the trapping hydrostatic pressure in order to prevent the escape of cell cytoplasm through the perforation.

[0035] More specifically, the present invention encompasses a microdevice for introducing molecules or substances into a plurality of cells, comprising (a) a single microfabricated array substrate having a plurality of individual microchambers, wherein each microchamber holds at least one cell and incorporates an integrated micro-piercing

injector; (b) a top planar substrate for entrapping individual cells in microchambers; and (c) a bottom planar substrate enclosing flow channels which run beneath said microchambers; wherein said microchambers and said flow channels are connected by individual inlet ports through said micro-piercing injectors.

[0036] Manufacturing the microdevice elements into the substrate may be carried out using microfabrication techniques known in the art including photolithography etching, plasma etching or wet chemical etching. Alternatively, micromachining methods such as laser drilling, micromilling and the like may be employed.

[0037] The molecules or substances to be introduced into the plurality of cells may be introduced into the cytoplasm (transformation) or the nuclei (transfection). The molecules or substances to be introduced may be any molecules or substances of interest, but are typically selected from the group consisting of DNA, RNA, ribozymes, molecular probes, hormones, growth factors, enzymes, proteins, drugs, organic chemicals, inorganic chemicals, viruses and expression vectors. Organelles such as nuclei, mitochondria, chloroplasts and the like may also be introduced into the cytoplasm of the target cells using the disclosed devices. Introduction of nuclei, for example, is particularly useful for technologies like cloning which employs nuclear transfer into a recipient oocyte.

[0038] The cells to be transformed by the present invention may be any cells of interest. In particular, the cells may be selected from the group consisting of somatic cells, oocytes, stem cells, mammalian cells, spleen cells, myeloma cells, and plant cells. Transfection of oocytes and stem cells may have particular use in the transfection of transgenes in the design of transgenic animals. Further, where the recipient cell is an oocyte, the material to be inserted may also be another cell, such as a sperm cell or a stem cell in the case of nuclear transfer into an enucleated oocyte. Methods of nuclear transplantation are well known in the art as evidenced by U.S. Patent No. 4,664,097 of the Wistar Institute, herein incorporated in its entirety, and such methods may be readily adapted for use on a micro-level in the devices of the present invention. The microdevices of the present invention are also useful for fusing spleen cells and myeloma cells, i.e., hybridoma technology, for the purpose of making monoclonal antibodies. For instance, U.S.

Patent No. 4,822,470 of the Baylor College of Medicine discloses a method for the poration and fusion of cells using radiofrequency electrical pulses in hybridoma technology and is herein incorporated by reference. Such applications could readily be accomplished using the micropores created by the present transformation devices. For instance, spleen cells from an immunized mammal could be isolated and entrapped into individual microwells of the disclosed devices, thereby being perforated and fused with a myeloma cell essentially simultaneously. The fused hybridoma cells could then be collected and screened for the production of antibodies having specific binding characteristics.

[0039] The microdevices of the present invention may be designed having microchambers of varying size to accommodate specific cell types. Preferred individual microchambers range in size from approximately 5 microns and above. Likewise, individual inlet ports may be designed in order to accommodate a specific molecule, substance or cell to be introduced into the target recipient cell in order to better control the amount of material entering cells during transformation. More specifically, inlet ports may range in size from about 1 micron and above.

[0040] The microfabricated array module of the present invention may be made of any material commonly used in the micromachining art. For instance, such materials include silica, silicon, silicon carbide and gallium arsenide to name a few. Preferably, the array substrate should be made of a microfabrication facilitating substance which may also be heated or cooled depending on the use of the device. The top and bottom planar substrates are most preferably glass, but may also be made of any suitable micromachining material such as silica, silicon, silicon carbide, gallium arsenide, glass, silicon elastomer (silicone), fused quartz, plastics and photo-etchable glass (Foturan™).

[0041] As described briefly above, the microdevice is designed with microfluidic flow channels beneath the microchambers that deliver biological and other molecules to the entrapped cells on the array. The device may be specially designed wherein independent, unconnected flow channels feed different groupings of microchambers for simultaneous targeting of different molecules or substances to different cells on the array. The microdevice may also include multiple layers of arrays, bottom and top substrates for

high throughput, and also for delivering different molecules simultaneously through independent, unconnected flow channels.

[0042] The cross-sectional dimension of an individual flow channel will depend on the particular application of the microdevice. For instance, if cells are to be transformed simultaneously with the same molecule or substance, one flow channel may feed more than one well in the array. Alternatively, individual unconnected flow channels may be designed for the purpose of feeding individual inlet ports. Flow channels may also be fluidly connected to a fluid feeding and/or direction system for introducing and/or directing said molecules or substances into said microdevice.

[0043] As described above, the microdevices of the present invention entrap cells into microchambers using applied hydrostatic pressure. The devices may be further equipped with a pressure means for pressurizing or applying pressure to the top substrate, whereby the amount of pressure may be easily controlled by the operator. Suction from below the trapped cells could also be used to assist in entrapment of cells, either independently or in conjunction with hydrostatic pressure.

[0044] The microdevices of the present invention are preferably designed with an array substrate that conducts heat, so that that cells may be heated or cooled depending on the micro-operation to be transformed. For instance, where heating of the cells facilitates the transformation process, the array substrate may be further connected to a heater element, and said heater further connected to an adjustable power source. A temperature sensor and monitoring means would also be incorporated so that the operator could readily adjust and monitor temperature levels. In some cases, it may be advantageous for the array substrate to be connected to a voltage supply which provides an adjustable electrical pulse, for instance, for nuclear transfer applications. Miniaturized devices such as heaters and voltage devices for carrying out a variety of synthetic and diagnostic operations are described in U.S. Patent No. 6,132,580 (The Regents of the University of California), which is herein incorporated by reference in its entirety.

[0045] The top planar substrate of the microdevices described herein may incorporate openings for washing away untrapped cells, and/or supplying or washing away medium or specific molecules or chemicals or radioactive labels to or from entrapped cells (see Fig. 1). The array substrate and/or top substrate may be optionally connected to a sample handling system that permits the transfer of cells from microchambers to outside analytical or collection devices.

[0046] A particularly useful sample handling system comprises individual exit ports for each microchamber, or groups of microchambers, wherein said exit ports are connected to individual flow channels.

[0047] Cells may be collected or routed into sample handling devices using any convenient means known in the art. For instance, the sample handling system may be further connected to a vacuum or pressure means for effectuating movement of said cells from said microchambers into said exit ports and/or said exit channels. Electrical currents and thermal expansion may also be used to effectuate sample movement. In this regard, U.S. Patent No. 5,872,010 (Northeastern University), herein incorporated by reference, describes "off-chip" microscale liquid handling systems whereby small quantities of a fluid sample from a spatially concentrated environment of a microscale device may be transferred through individual exit ports to a collection device without an increase in sample volume. Similar techniques may be applied to the chips of the present invention following cell transformation using exit port adaptors and flow channels. Cell-sorting using magnetically tagged cells and an external magnetic field could also be used.

[0048] Outside analytical or collection devices which may be used in conjunction with the microdevices described herein include secondary microfabricated arrays of microchambers or multiwell plates, e.g., for culturing cell populations from individual transformed cells; filters or films for conducting hybridization, e.g., Southern, Northern and Western analyses; apparatus for receptor/ligand analyses, e.g. screening transformed cells for those which express a particular ligand or receptor and bind to another molecule or protein of interest; apparatus for immunological screening, e.g., of antibody producing hybridoma cells; devices for radioactivity measurements, e.g., of transformed cells

labeled with a radioactive isotope; flow cytometry or FACS apparatus, e.g. to screen cells for the expression of surface proteins encoded by transfected genes or for other changes in gene expression; mass spectrometry or nuclear magnetic resonance analyses, chromatography, and fluorescence imaging.

[0049] The present invention also includes methods of using the disclosed microdevices for introducing molecules or substances simultaneously into a plurality of cells, and also the transformed, transfected or fused cells produced thereby. Methods of using the transformed cells for diagnostic applications and further analyses as proposed above are also included. For instance, the transformed cells of the present invention could be used to identify genes of interest, for high throughput hybridoma screening and efficient identification and isolation of monoclonal antibodies, for the production of useful proteins, for the screening of drugs and pharmaceuticals, and for the production of transgenic animals.

[0050] The present invention may be distinguished from silicon chip-based micro-injection techniques of the prior art by the single module nature of the microchamber/injection apparatus. Accordingly, the present invention includes a method for simultaneously positioning and perforating a plurality of cells, comprising (a) positioning cells on a single microfabricated array substrate that incorporates integrated micro-piercing structures within microchambers; and (b) entrapping cells in said microchambers using hydrostatic pressure applied from above such that said cells are perforated by said micro-piercing structures. Molecules, substances, organelles or other cells of interest may be introduced into or extracted from said plurality of cells during perforation. The microdevice may also be used to remove cellular contents for the purpose of isolating cell membranes, e.g., erythrocyte ghosts. Typically, the plurality of cells is exposed to said molecules, substances, organelles or other cells of interest by way of a flow channel encased by a bottom substrate underneath said array substrate.

[0051] Also included in the present invention are kits comprising the disclosed microdevices, which may optionally comprise accessory devices such as a heater and power source for altering the temperature of the array substrate. Although one advantage of the microdevices described herein is ease of manufacture and the feasibility of mass production,

microdevices may also be custom design according to a particular cell type, transformation application or desired analytical apparatus. Heating units may also be built into the microdevice array substrate rather than sold as a separate unit. Kits of the present invention may further comprise a sample handling system comprising individual exit ports and flow channels for each microchamber or group of microchambers, which may be optionally connected to a vacuum or pressure means for effectuating movement of said cells from said microchambers into said exit ports and/or said exit channels for subsequent analysis or collection.

[0052] The present invention is further described by reference to the following examples, that are intended for purposes of illustration only and should not be construed to limit the scope of the claimed invention.

Example 1

[0053] The microdevice structure (Fig. 1) is based on a single chip module containing a large array of microchambers in a silicon substrate that houses recipient cells to be transformed (Fig. 1). Inlet ports located at the bottom of each microchamber are integrated into the device in such a way as to simultaneously render micro-piercing injectors during microchamber fabrication (Fig. 2). The silicon structure is bonded with a glass substrate on the top in order to introduce recipient cells into the microsystem, and to allow the application of hydrostatic pressure. A glass substrate is also bonded to the bottom of the device, which contains the micro-fluidic channels for biological and molecular component transport (Fig. 1).

[0054] Initially, the cells are allowed to settle onto the bottom of each microchamber, and when all microchambers are filled by the cells, hydrostatic pressure is applied from above to trap and hold them in place. During the entrapment process, the cell membranes are perforated mechanically by the micro-piercing structures. The inlet ports then act as micro-injectors through which biological material and/or molecules can be introduced into the cell using positive pressure. This pressure is applied shortly after the application of the trapping hydrostatic pressure from above in order to prevent the escape of cell cytoplasm through the perforation.

[0055] Aside from the various standard integrated circuit processing requirements, the fundamental fabrication steps involve silicon micromachining, from simple bulk micromachining to deep reactive ion etching (DRIE) procedures. Similarly, for the top and bottom glass substrates, wet chemical etching will be necessary to create fluidic channels for cell and material transport.

[0056] First Embodiment: device based on etched microchambers
Isotropic Etching

[0057] The core aspect of this microdevice is the creation of the injector structure during the same time that the micro-chambers are being formed. The use of isotropic etchants is ideal for the formation of the desired profile in silicon. The ability to etch silicon crystal planes at the same rate in all directions is the defining characteristic of isotropic etchants. By using a masking layer that is not attacked by a given isotropic etchant, a pattern can be lithographically printed in the mask to expose certain areas of silicon to the ambient. The chemistry of the etching process produces an attack of the silicon material underneath the masking layer, due to the etchants' isotropic nature, thereby creating a hemispherical cavity within the silicon substrate. The undercutting of the masking layer, illustrated in Fig. 3, can be used to great advantage for the simultaneous creation of a micro-chamber and micro-injector structure.

[0058] The masking pattern should therefore be designed in order to form a circular cavity within the silicon substrate to hold the recipient cell, with a sharp protrusion at the bottom of each cavity to form the injector. This etch profile can be accomplished with an annulus or donut-shaped masking pattern where the area between the two concentric circles is bare silicon, and therefore, the region to be etched. The inner circle acts as a mask over which the isotropic etchant would remove the silicon, by means of undercutting, to create the protrusion while the outer circle will provide the radial dimension of the resulting cavity. The top and cross-sectional views of the masking pattern have been shown in Fig. 4.

[0059] Either wet or dry isotropic etching can be performed, where the former consists of wet chemistries, typically a mixture of hydrofluoric acid (HF), nitric acid

(HNO₃), and acetic acid (CH₃COOH). This etchant, referred to as "HNA" has some limitations in its use because the resulting etch profile is highly agitation-dependant and sensitive to temperature (Madou 1997). In addition, it is difficult to mask with any precision since HNA can etch the masking layer very quickly. This makes it quite difficult to control lateral undercutting as well as vertical etch depth. Dry isotropic etching is further divided into plasma-assisted etching and gas-phase etching. Plasma-assisted etching involves creating an area of high energy electric and magnetic fields in a vacuum chamber that cause a gas to dissociate to form highly energetic ions, photons, electrons, and reactive radicals and molecules, which establish the etching process. Thus, with this type of reactive ion etching (RIE), various etch profiles can be achieved by adjusting the chemistry and flow rates of the gases involved. Etch cavities can range from isotropic to profiles with near-vertical sidewalls. The RIE species to be used for the proposed microdevice will be sulfur hexafluoride (SF₆), which will etch silicon but that does not adversely affect an aluminum masking layer.

[0060] Gas-phase etching is always accomplished using xenon difluoride (XeF₂) to generate etching species without the need of a plasma (Madou 1997). Xenon difluoride is a white crystalline solid at room temperature and atmospheric pressure, having a vapor pressure of about 4 Torr at these conditions [Ann]. Exposed areas of silicon etch in the vapor, or dry, phase at room temperature and at pressures between 1 to 4 Torr, which can be established by a simple vacuum pump. XeF₂ exhibits a high selectivity to silicon over such common masking materials as silicon-oxide (SiO₂), silicon-nitride (Si₃N₄), aluminum, and photo-resist.

[0061] By controlling the isotropic etch duration of the masking pattern shown in Fig. 4, the resulting micro-cavities formed in the bulk silicon substrate have slight yet important differences. In Fig. 5, the progression of etch time duration is illustrated, with the shortest amount of time given by (a), and the longest given by (c). From Fig. 5, it is apparent that in order to form a micro-chamber with a protruding micro-injector at the bottom of each cavity, the profile of the two individual etches must come into contact. In Fig. 5a, the etch time is not long enough to permit contact, so that after the mask is removed, a flat silicon plateau will remain between the two etch cavities. In Fig. 5b, the etch cavities

are touching, which would indeed create a protruding micro-injector. However, for a truly robust microdevice, the height of the micro-injector should ideally be contained entirely within the confines of the micro-chamber in order to avoid the possibility of damage during either device fabrication or operation. Therefore, by allowing the two etch cavities to merge, as shown in Fig. 5c, a recessed micro-injector is formed at the same time the micro-chamber is defined.

[0062] With the micro-injectors and micro-chambers in place, the inlet port must be incorporated into the micro-piercing injectors in order to allow the transfer of biological materials or molecules. The inlet port would simply need to be a small access tube starting at the back-side of the silicon wafer, terminating at the tip of the micro-injector. The technique used to fabricate such a hole relies on dry anisotropic etching using highly reactive ion species to chemically attack the silicon substrate.

[0063] Finally, wet isotropic etching will also be used to create the micro-fluidic channels in the top and bottom glass substrates. The substrates will then be aligned and bonded to the silicon wafer using high temperature and high voltage anodic bonding techniques. The glass will be either a standard pyrex-7740 wafer or the newer Foturan photo-etchable glass substrate. Both have thermal expansion coefficients similar to silicon and therefore introduce no stress when anodically bonded at high temperatures. Both 7740 and Foturan are etched in hydrofluoric (HF) acid.

Anisotropic Etching

[0064] Anisotropic etching of silicon is a fundamental technology required in the fabrication of both the inlet ports, and of the back-side reservoirs where the biological material or molecules will be stored prior to insertion into the recipient cells. The quaternary alkaline silicon etchant known as tetra-methyl ammonium hydroxide (TMAH) will be used to create the back-side reservoirs. Typically, wet anisotropic solutions have crystallographic-dependant etch rates, and for TMAH, the $\langle 111 \rangle$ planes of the silicon crystal lattice etch the slowest with respect to $\langle 100 \rangle$ and $\langle 110 \rangle$ planes. For a (100) oriented wafer, etch profiles are usually in the form of inverted pyramidal cavities aligned with the wafers' $\langle 110 \rangle$ primary flat. The slopes of the pyramidal pit correspond to the $\langle 111 \rangle$

planes, which intersect the $\langle 100 \rangle$ plane at 54.7° . This is the reason why the back-side of the microdevice in Figs. 1 and 2 have sloping sidewalls, which correspond to the $\langle 111 \rangle$ planes.

[0065] In contrast, reactive ion etching, or RIE, is a dry anisotropic process that is not dependent on crystal planes. Rather, the etch profile produced by RIE ranges from a relatively isotropic-like nature to a profile with near-vertical sidewalls, as mentioned earlier. With a new technology known as deep reactive ion etching (DRIE), holes can be made in a silicon wafer which extend from the front-side to the back-side with nearly vertical sidewalls. This technology will be used for creating the inlet ports in the micro-injectors. Based on Fig. 5, if the masking layers were removed from each of the cross-sectional views, then with the inlet port in place, the devices would appear as shown in Fig. 6.

Fabrication Process Flow

[0066] Fabrication of the microsystem will follow two parallel processes, with one involving an ultra-thin 4" silicon wafer while the other employing a 4" SOI, or silicon-on-insulator wafer. Testing of specific process flow steps will be performed on standard 4" silicon wafers. The reason for using either ultra-thin or SOI wafers is because the overall diameter of the cavity is being designed for 10 μm , to accommodate cells of comparable sizes. Therefore, the isotropic etch that creates such a cavity will etch downwards by only 5 μm , since the diameter is formed by undercutting the masking layer on all sides of the circular annulus. Deeper cavities to accommodate the cells should be made by performing a relatively anisotropic RIE process. The thickness of the ultra-thin wafer will be approximately 20 μm whereas the SOI wafer will be that of standard thickness, typically 500 μm . It is clear that by a fabrication standpoint, the SOI wafer will be easier to handle and process as compared with the ultra-thin wafer, which can prove to be difficult to handle due to their fragility. The fabrication process for both types of wafer has been given in Fig. 7. Both processes are somewhat equivalent, beginning with a silicon surface oxidation followed by a DRIE step to create the inlet port. However, for the ultra-thin wafer, the lithography defining the pattern for the inlet port using DRIE is done on the back-side of the wafer, while for the SOI, it is done on the front. Once the DRIE has been done, the original silicon-dioxide layer is removed and a new layer of SiO_2 is grown on all exposed silicon surfaces, including within the inlet port hole. Both wafers undergo the second lithographic step on the front-side that is used to define the annuli, each being centered and aligned with the inlet port hole. Once defined, an anisotropic RIE step can be applied in order to increase the depth of the resulting micro-cavity, followed by an isotropic etch. This dry etch procedure can be made in two ways, and investigations will be made with either xenon-difluoride gas-phase etching or with sulfur hexafluoride plasma etching. The result of this step is the creation of a micro-cavity similar to that shown in Fig. 6c. For the SOI wafer, an additional step is required before the SiO_2 can be removed from both of the wafers. Since the SOI wafer is thick and the inlet port still inaccessible (refer to Fig. 7), an additional back-side anisotropic bulk silicon etch is needed using TMAH solution. The final micro-cavity with integrated piercing structures results in both cases.

Results

[0067] A series of trials were run to determine the optimal etching strategy for producing the microdevice. KIC software (developed at the University of California at Berkeley) was used to design a mask for etching an array of annuli of varying dimensions. The masks were printed on a linotronic output transparency at a local desktop publishing company resulting in annuli with a resolution of about 20 microns, sufficient for initial testing of etching procedures. The annuli had inner radii ranging from 10 to 30 microns in increments of 10 microns, and outer radii ranging from 20 to 60 microns in increments of 10 microns.

[0068] XeF_2 etching was attempted at first but proved unsuccessful, possibly due to the formation of a polymer-like film on the silicon surface during the etch procedure. Baking the silicon at 140°C for a short time (~10 minutes) may remove the unwanted surface adherents prior to etching which should produce more favorable results. This experiment will be re-attempted in the future.

[0069] Sulfur hexafluoride etching proved more successful. Initially, tests were conducted using an oxide masking layer to determine the relative isotropy of the RIE recipe. Simple test structures were etched to determine etch profile, as shown in the scanning electron micrograph (SEM) micrograph of Fig. 8. Aluminum was deposited on a silicon wafer, followed by photoresist, placement of the mask, UV illumination, aluminum etch, and finally SF_6 etch. An SEM of a portion of the resultant array of annuli is shown in Fig. 9. SEMs of two micro-cavities in the array are shown in Figs. 10 and 11. Their surface topography scans are also given in Figs. 12a and b, respectively. The depth of the two micro-cavities are equal because both were parts of the same array that were etched for equal times. But since their dimensions (inner and outer diameters), are different due to the different annuli masking dimensions, the inner projection that forms the micro-injector has a different height. None of the smallest diameter annuli (10 micron inner diameter) patterned successfully, due to the limited resolution of the mask. It should be evident that the annuli profiles are not clean surfaces and exhibit tremendous roughness. This is due to the aluminum masking layer that was used since the RIE procedure affects the aluminum causing it to precipitate onto the etching silicon surface. As a result, the aluminum on the

etch front produces a micro-masking effect leading to excessive surface roughness. This problem can be alleviated by the use of an oxide masking layer. Indeed, as seen in Fig. 8, the etch profile is clean and there is no surface roughness on the silicon that is etched. The aluminum masking layer was used since it is a quick procedure to deposit, and could also be used for masking in a XeF_2 environment.

[0070] A second series of experiments were conducted to characterize important etch processes, using mask geometries larger than those of the final microstructure, to determine a microfabrication strategy that would produce the micro-injector structure illustrated in Fig. 1. The results obtained in conjunction with these experiments are shown in Figures 13-16. Reactive Ion Etching (RIE) tests for silicon isotropic/anisotropic etching were performed to determine the optimal recipe for our final device. A mixture of O_2 and SF_6 gases were introduced into the RIE in various proportions and a plasma was struck at different power levels. Investigations were made of both silicon (Si) and silicon dioxide (SiO_2) etch rates, the etch selectivity between Si and SiO_2 , and the degree of anisotropy of the etch. The test structure, shown in Fig. 2, consisted of a series of annuli patterned in silicon, masked by a thermal oxide layer. The annuli had inner radii ranging from 30 to 60 microns in increments of 10 microns, and outer radii ranging from 50 to 100 microns in increments of 10 microns, with a resolution of about 20 microns, sufficient for initial testing of etching procedures. All etches were performed for 5 minutes at 85 mTorr, and etch depths were measured using a Dektak profilometer. The mask underetch data was visually determined using an optical microscope while calculations were performed to arrive at the selectivity, etch rate, and anisotropy. Graphical results for only three trials are discussed below.

[0071] These experiments helped determine the RIE recipe to form the final micro-needle structure, taking into account the desired shape, etch depth, and mask underetch rate. It was concluded that the anisotropy of the final etch be between 1 and 2, while a selectivity of greater than 100 is also preferred. The lower power RIE using 95W RF power is more desirable because the resulting etched surface is smoother than with other power levels. It was also determined that a 10% O_2 and 90% SF_6 gas mixture yielded a suitable etch profile, and that a pressure between 80 to 90 mtorr gave the best results since it

provided high selectivity. Pressure does not greatly affect the anisotropy, however experiments revealed that higher pressures correlated to both higher selectivities and Si etch rates. For the CTM micro-needle fabrication, the recipe to be used will have a 10% O₂-90% SF₆ gas mix at 85mtorr and 95W RF power.

[0072] The inlet port in the micro-injector structure (Fig. 1) can be fabricated through a commercial MEMS service provider possessing Deep-RIE (DRIE) technology ideal for etching a 1-2 μm diameter holes in the silicon substrate to a depth of about 30 μm.

[0073] In addition to characterizing the RIE, the method by which hydrostatic pressure is applied was further analyzed with the aid of a macro-model of the CTM, shown in Fig. 17. In the original design, manual syringes located at ports A, B, C, and D (Figs 17) are used in the microsystem to control the hydrostatic pressure (A), to transport the recipient cells before and after injection (B and C), and to allow the transfer of material into the host cells (D). This concept assumed an empty (air-filled) micro-needle that acts as a stiff damping element. The application of large hydrostatic pressures in this design will not necessarily impel the recipient cells to be seated in their respective micro-chambers, and could potentially break the silicon membrane. Furthermore, the added pressure would displace the air in the micro-needle downward due to the piston-like action of the free moving syringe (D). At the time of injection, it is likely that this displaced air would be introduced into the cell, and since fluid inside the cell is incompressible, the cell may be forced off the micro-needle with little or no material being inserted. Alternatively, the material to be injected could be pre-loaded in the micro-needles (fluid-filled) prior to injection, however, due to the lack of venting below the cells to be trapped, the design does not allow for the downward displacement of cells by the action of increased hydrostatic pressure. The result is that the cells are not seated in the micro-chambers due to the incompressibility of fluid below the cell. The shortcoming of the design is that the micro-injector is used during both cell trapping and material injection phases. To improve the probability of cell seating and material injection, the initial design was modified to allow for venting of the fluid trapped below the cells as they are pushed down onto the micro-needles. Ports were considered for the design (Fig. 18) to provide a means for fluid escape during the cell trapping operation, allowing the micro-injectors to be pre-loaded with the material to be introduced. However, since the 30-40 μm deep vent and inlet ports would be made using

DRIE, an *optimistic* minimum diameter for each hole, taking into account some unavoidable lateral etch, would be about 1.5 μm . Considering the micro-chamber is a 10 μm diameter cup, designed to be slightly less than the size of a host cell, performing lithography and processing in such a confined space would be difficult. A new design incorporating fluidic channels for venting and suction was developed, and is described in the next section.

[0074] Second Embodiment: device based on microchambers obtained by molding PDMS substrate.

[0075] In a second embodiment of the invention a design was conceived that eliminated the etched micro-chambers so the micro-needle array could be formed on the silicon surface. An intermediate structural layer made of polydimethylsiloxane (PDMS) silicone rubber, which uses standard silicon micro-technologies and a molding method for processing, was added between the silicon and top glass substrate. This new layer contains an array of micro-tubes 10 μm in diameter that are aligned above the micro-needle array on the silicon. The micro-tubes are the seating locations for the host cells, which are drawn into these holes using a combination of applied hydrostatic pressure applied and suction through the fluidic channels formed in the PDMS layer, as depicted in Fig. 19. This design alleviates the need of isotropically etched micro-chamber fabrication, thereby eliminating the need for costly ultra-thin or silicon-on-insulator (SOI) wafers, which were in the original proposal. Since the microsystem is fabricated with standard silicon wafers, backside anisotropic etching is used to access the micro-needle injector ports. PDMS will also be used to *backfill* this large etch cavity to reduce its volume thereby reducing the amount (cost) of material to be injected. Fabrication of the top silicone layer relied on casting uncured PDMS onto a double-spun epoxy-based thick SU-8 photoresist mold that was patterned with the fluidic channels and micro-chamber. After the PDMS had cured, it forms a durable device that can be peeled from the mold. Experiments were conducted to find the best recipe for a double-spun SU-8 layer and to find a sacrificial release layer between the PDMS and SU-8 for ease of microstructure removal. Results obtained in connection with this embodiment of the invention are shown in Fig. 20.

Testing the Microsystem

[0076] Initial testing of the microdevice will determine if cells can be successfully pierced by the microinjectors and fluid injected. Fluorescent dye will be put in the lower reservoir of the microdevice and mammalian cells in the upper reservoir. The cells will be allowed to settle into the cavities, pressure in the upper reservoir will be increased until the cells are punctured, a pressure pulse applied to fluid in lower chamber to eject dye laden fluid into the cells. Cells not trapped in the cavities will be removed by a small flow of fluid horizontally in the upper chamber. The whole process will be observed in real time via a microscope with fluorescent capability. The cells will finally be removed from the microdevice and examined for successful injection of fluid by the presence of fluorescence.

[0077] For testing the microdevice to successfully transfect cells, we proceed as follows (Maniatis1989): A commercial vector designed for transfection of mammalian cells and which contains a gene for expression of green fluorescent protein will be loaded into the microdevice and injected into cells as described above. The injected cells will be assayed for viability by growth as clones on agar. Within a few hours of injection, single cells will be assayed for successful transfection and expression by assay under fluorescence microscopy following inoculation onto a polylysine coated coverslip. For expression of larger soluble proteins, cells will be injected with an expression vector for beta-galactosidase and clones assayed by a commercial color development assay. For nervous system genes, commercial vectors will be cut with appropriate restriction enzymes followed by insertion of cDNA that specifies a protein of interest, such as carboxypeptidase II or the metabotropic glutamate receptor subtype 1. Clones will be assayed by standard methods used in Professor Neale's laboratory, substrate hydrolysis for the enzyme and receptor mediated increase in intracellular calcium for the receptor.

3.6 Significance of the Project and its Clinical Potential

[0078] Techniques for the incorporation of exogenous molecules into cells has advanced the determination of pathways of a variety of protein synthesis, enzymatic and immune system processes, in vitro testing of drugs, and gene therapy. Such techniques have therefore become critical tools in cellular and genetic research, as well as in therapeutic applications. Improved methods for delivering molecules to cells is therefore critical for the

advancement of basic research, biotechnology and for clinical applications. One such clinical application, gene therapy holds the promise of revolutionizing the treatment of disease. There are over 4000 genetic diseases, and virtually every disease is influenced by a genetic component. Gene therapy consists of the introduction of DNA that encodes a specific protein into cells to produce a therapeutic effect, such as the production of an enzyme that the cell is unable to produce due to a defective gene. In *ex vivo* transfection, defective cells are removed from the body, transfected, and returned to the body. The first human gene therapy trial was for the treatment of an immunodeficient disease resulting from the inability of the body to produce the enzyme adenosine deaminase (ADA). Lymphocytes were isolated from a patient, exposed to a retrovirus carrying the ADA gene, and then returned to the patient. A more recent application uses transfection as insulin replacement therapy. Non-B-cell somatic cells removed from a diabetic patient were genetically altered *ex vivo* to produce and secrete insulin (Bailey et al 1999). Reimplantation of these transfected cells into the patient will theoretically obviate the need for insulin injections. Another promising area is in tumor immunization. Here, cells from the patient's tumor are removed, transfected with retroviral vectors containing either IL-2 or tumor necrosis factor (Rosenberg SA 1992, 1993). The cells are then injected back into the patient where they may increase the immune response to the bulk tumor. Our project will develop a silicon based microdevice to improve *ex vivo* transfection. Most current transfection methods suffer from one or more liabilities, resulting in low transfection rates. Our proposed device presents an improved methodology for transfection (and more generally for the introduction of any type of molecule into cells) over the current state-of-the-art. In particular, the device will: require minimally skilled expertise, handling and expenditure of time transform large numbers of cells in a single step maintain cell viability in a high percentage of cells be cost-effective overcome limitations inherent in other transfection microfabricated devices such as complex fabrication processing and device fragility, by using a simplified device fabrication strategy developing a single component device inherently more durable and robust than the current two component devices.

References:

- Bailey CJ, Davies EL, Docherty K (1999). Prospects for insulin delivery by ex-vivo somatic cell gene therapy. *J. Mol. Med.* 77, 244-249.
- Chun K, Hashiguchi G, Toshiyoshi H and Fujita H (1999). An array of hollow microcapillaries for the controlled injection of genetic materials into animal/plant cells. Twelfth IEEE International Conference on Micro Electro Mechanical Systems, 406-411, (Jan. 17-21) Orlando, Florida.
- Gainer AL, Korbitt GS, Rajotte RV, Warnock GL, Elliott JF (1996). Successful biolistic transformation of mouse pancreatic islets while preserving cellular function. *Transplantation* 61, 1567-1571.
- Klein TM, Arentzen R, Lewis PA and Fitzpatrick-McElligott S (1992). Transformation of microbes, plants and animals by particle bombardment. *Biotechnology* 10 286-291 (1992).
- Klein TM, Wolf ED, Wu R, and Sanford JC (1987). High velocity microprojectiles for delivering nucleic acids into living cells. *Nature* 327, 70-73.
- Le Pioufle Surbled P, Nagai H, Chun KS, Murakami Y (1999). Tamiya E, and Fujita H, Attachment of Cells on Microsystems: Application to the Gene Transfection. *Transducers '99*, 768-771. The 10th Annual Conference on Solid State Sensors and Actuators, (June 7-10) Sendai, Japan.
- Levine F and Friedmann T (1993). Gene Therapy. *Am J Dis Child* 147, 1167-1174.
- Madou Marc (1997). *Fundamentals of Microfabrication*. CRC Press, Boca Rotan.
- Maniatis T, Fritsch EF, and Sambrook J (1989). *Molecular cloning: a laboratory manual*, 2nd ed. Cold Spring Harbor, N.Y. Cold Spring Harbor Laboratory.
- McAllister DV et al (1999). Three-dimensional hollow micro-needle and micro-tube arrays. *Transducers* 1098-1101 (June 7-10) Sendai, Japan.
- Madry H, Trippel SB (2000). Efficient lipid-mediated gene transfer to articular chondrocytes. *Gene Therapy*, 286-291.
- Miller AD (1992). Retroviral vectors. *Curr. Top. Microbiol. Immunol.* 158, 1-24.
- Morgan RA and Anderson WF (1993). Human Gene Therapy. *Annu Rev Biochem* 62, 191-217.

Mullen CA, Snitzer K, Culver KW, Morgan RA, Anderson WF, Blaese RM (1996). Molecular analysis of T lymphocyte-directed gene therapy for adenosine deaminase deficiency: long-term expression in vivo of genes introduced with a retroviral vector. *Gene Therapy* 7, 1123-29.

Neumann E, Sowers AE, and Jordan CA (1989). *Electroporation and Electrofusion in Cell Biology*. Plenum Press, New York.

Pelicer A, Robins D, wold B, Sweet R and Jackson J (1980). Altering genotype and phenotype by DNA mediated gene transfection. *Science* 209, 1414-1422.

Rosenberg SA, Anderson WF, Blaese M, Hwu P, Yannelli JR, Yang JC, Topalian SL, Schwartzentruber DJ, Weber JS and Ettinghausen SE (1993). The development of gene therapy for the treatment of cancer. *Ann Surg* 218, 455-463.

Rosenberg SA (1992). *Human Gene Therapy* 3, 57-73.

Thompson DC, Frazier-Jessen MR, Rawat R, Nordan RP, and Brown RT (1999). Evaluation of methods for transient transfection of a murine macrophage cell line, RAW 264.7, *Biotechniques* 27, 824-826.

What is claimed:

1. A microdevice for introducing molecules or substances into a plurality of cells, comprising:

(a) an array substrate having a plurality of individual microchambers, wherein each microchamber is suitable for holding at least one cell and incorporates an integrated micro-injector;

(b) a top planar substrate for introducing and entrapping individual cells in microchambers positioned above the array; and

(c) a bottom planar substrate enclosing one or more flow channels which run beneath said microchambers positioned below the array at an opposite side of the top planar substrate;

wherein said microchambers and said flow channels are connected by individual inlet ports through said micro-injectors.

2. The microdevice of claim 1, wherein said molecules or substances are introduced into the cytoplasm of said cells.

3. The microdevice of claim 1, wherein said molecules or substances are introduced into the nuclei of said cells.

4. The microdevice of claim 1, wherein said molecules or substances are selected from the group consisting of DNA, RNA, ribozymes, molecular probes, hormones, growth factors, enzymes, proteins, drugs, organic chemicals, inorganic chemicals, viruses and expression vectors.

5. The microdevice of claim 2, wherein said substances are organelles.

6. The microdevice of claim 5, wherein said organelles are nuclei or mitochondria.

7. The microdevice of claim 1, wherein said cells are selected from the group consisting of somatic cells, oocytes, stem cells, mammalian cells, spleen cells, myeloma cells and plant cells.
8. The microdevice of claim 7, wherein said substances are other cells.
9. The microdevice of claim 8, wherein said cells are oocytes, and said other cells are selected from the group consisting of sperm cells and somatic cells.
10. The microdevice of claim 8, wherein said cells are spleen cells, and said other cells are myeloma cells.
11. The microdevice of claim 1, wherein said plurality of individual microchambers are formed in a polydimethylsiloxane (PDMS) silicone layer.
12. The microdevice of claim 11, wherein the microchambers are in the form of microtubes formed in the layer.
13. The microdevice of claim 12, wherein the microtubes are formed by molding the PDMS layer.
14. The microdevice of claim 12, wherein the microtubes have a diameter of about 10 micrometers.
15. The microdevice of claim 12, wherein one or more holes are formed in the PDMS layer, wherein said holes are in communication with the microtubes to form fluidic channels thereby allowing the positioning of the cells in the microtubes through succession.
16. The microdevice of claim 15 further comprising PDMS backfill member positioned below the bottom substrate at a face of the bottom substrate opposite the array of microtubes.

17. The microdevice of claim 1, wherein said cells are entrapped in said microchambers by applied pressure from said top planar substrate and/or by suction through bottom substrate.

18. The microdevice of claim 1, wherein said single microfabricated array substrate is made of a material selected from the group consisting of silica, silicon, silicon carbide, gallium arsenide, glass, silucon elastomer (silicone), fused quartz, plastics and photo-etchable glass.

19. The microdevice of claim 1, wherein said top planar substrate is made of material selected from the group consisting of silica, silicon, silicon carbide, gallium arsenide, glass, silucon elastomer (silicone), fused quartz, plastics and photo-etchable glass.

20. The microdevice of claim 1, wherein said bottom planar substrate is made of material selected from the group consisting of silica, silicon, silicon carbide, gallium arsenide, glass, silucon elastomer (silicone), fused quartz, plastics and photo-etchable glass.

21. The microdevice of claim 1, wherein independent, unconnected flow channels feed different groupings of microchambers for targeting different molecules or substances to said cells.

22. The microdevice of claim 1, wherein said microdevice includes multiple layers of said array, bottom and top substrates.

23. The microdevice of claim 22, wherein said multiple layers incorporate independent unconnected flow channels.

24. The microdevice of claim 1, wherein the cross-sectional dimension of an individual flow channel is about 1 micron or above.

25. The microdevice of claim 1, wherein said flow channels are fluidically connected to a fluid feeding and/or direction system for introducing and/or directing said molecules or substances into said microdevice.

26. The microdevice of claim 1, further comprising pressure means for pressurizing said top substrate to entrap said cells into said microchambers.

27. The microdevice of claim 1, wherein said array substrate and/or top substrate may be optionally connected to sample handling system that permits the transfer of cells from microchambers to outside analytical or collection devices.

28. The microdevice of claim 27, wherein said sample handling system comprises individual exit ports for each microchamber, or which serve a group of microchambers, and wherein said exit ports are connected to individual flow channels.

29. The microdevice of claim 28, wherein said sample handling system is further connected to a vacuum or pressure means for effectuating movement of said cells from said microchambers into said exit ports and/or said exit channels.

30. The microdevice of claim 27, wherein said outside analytical or collection devices include secondary microfabricated arrays of microchambers or multiwell plates, filters or films for conducting hybridization, receptor/ligand analyses, immunological screening or radioactivity measurements, flow cytometry or FACS apparatus, mass spectrometry or nuclear magnetic resonance analyses, chromatography and fluorescence imaging.

31. A method of introducing molecules or substances into a plurality of cells using the microdevice of claim 1.

32. The cells produced by the method of claim 31.

33. A method of introducing molecules or substances into a plurality of cells using the microdevice of claim 2.

34. The transformed cells produced by claim 33.

35. A method of introducing molecules or substances into a plurality of cells using the microdevice of claim 3.

36. The transfected cells of claim 35.

37. A method of fusing cells using the microdevice of claim 9.

38. The nuclear transfer units produced by the method of claim 37.

39. A method of fusing cells using the microdevice of claim 10.

40. The hybridoma cells produced by the method of claim 39.

41. A method for simultaneously positioning and perforating a plurality of cells, comprising:

(a) positioning cells on a single microfabricated array substrate that incorporates integrated micro-piercing structures within microchambers; and

(b) entrapping cells in said microchambers using hydrostatic pressure applied from above and/or suction from below such that said cells are perforated by said micro-piercing structures.

42. The method of claim 41, wherein molecules, substances, organelles or other cells of interest are introduced into said plurality of cells during perforation.

43. The method of claim 42, where said molecules, substances, organelles or other cells are introduced into the cytoplasm of said cells during perforation.

44. The method of claim 42, wherein said plurality of cells is exposed to said molecules, substances, organelles or other cells of interest by way of a flow channel encased by a bottom substrate underneath said array substrate.

45. The method of claim 41, wherein a cellular component or cell contents are extracted from cells during perforation.

46. The transformed, transfected or fused cells produced by the method of claim 42.

47. The cell membranes, components or contents isolated using the method of claim 45.

48. A kit comprising the microdevice of claim 1.

49. The kit of claim 48 further comprising a heater and power source for altering the temperature of the array substrate.

50. The kit of claim 48 further comprising a sample handling system comprising individual exit ports and flow channels for each microchamber or group of microchambers, which may be optionally connected to a vacuum or pressure means for effectuating movement of said cells from said microchambers into said exit ports and/or said exit channels for subsequent analysis or collection.

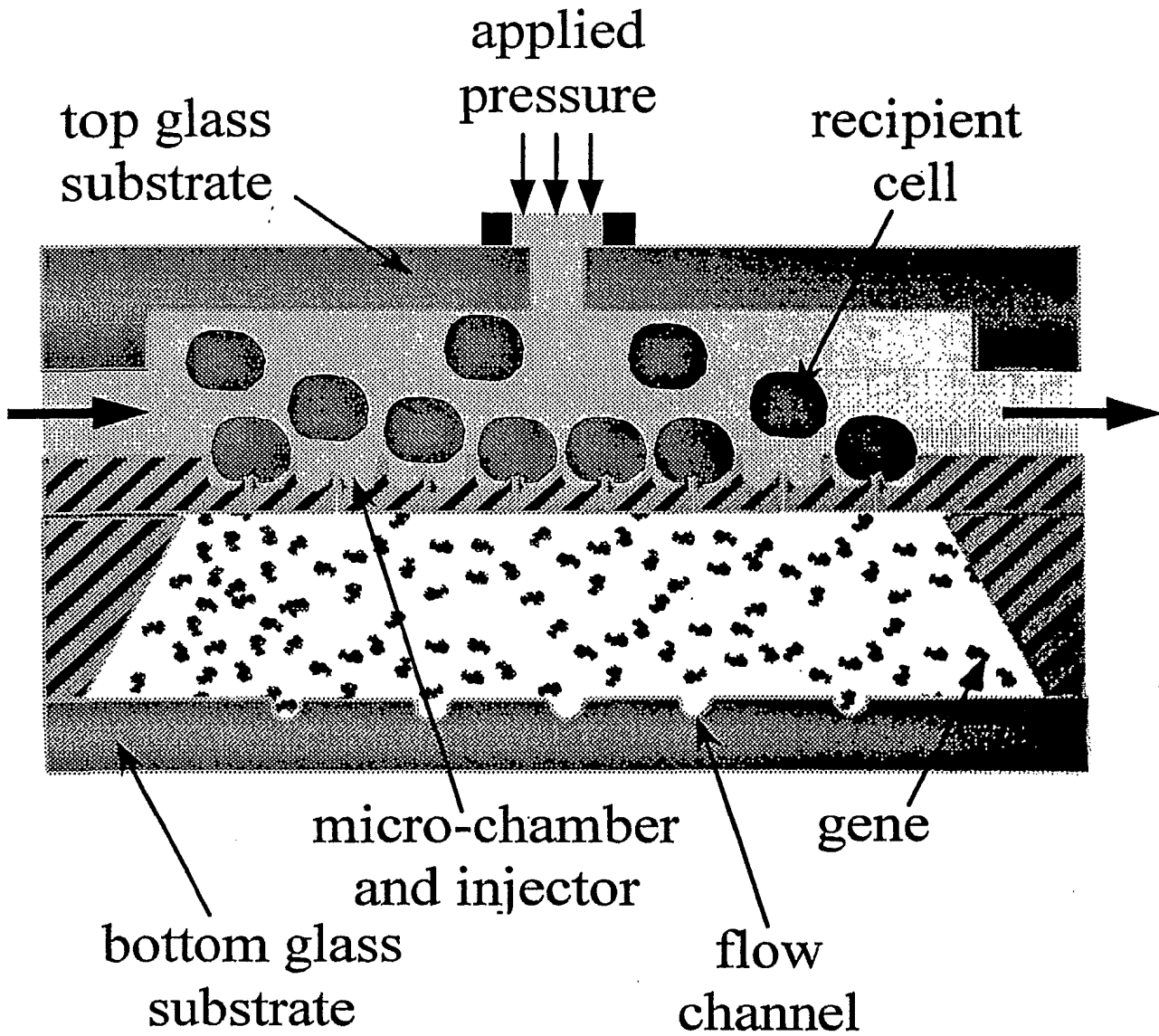

Fig. 1. Cell Transformation Microdevice

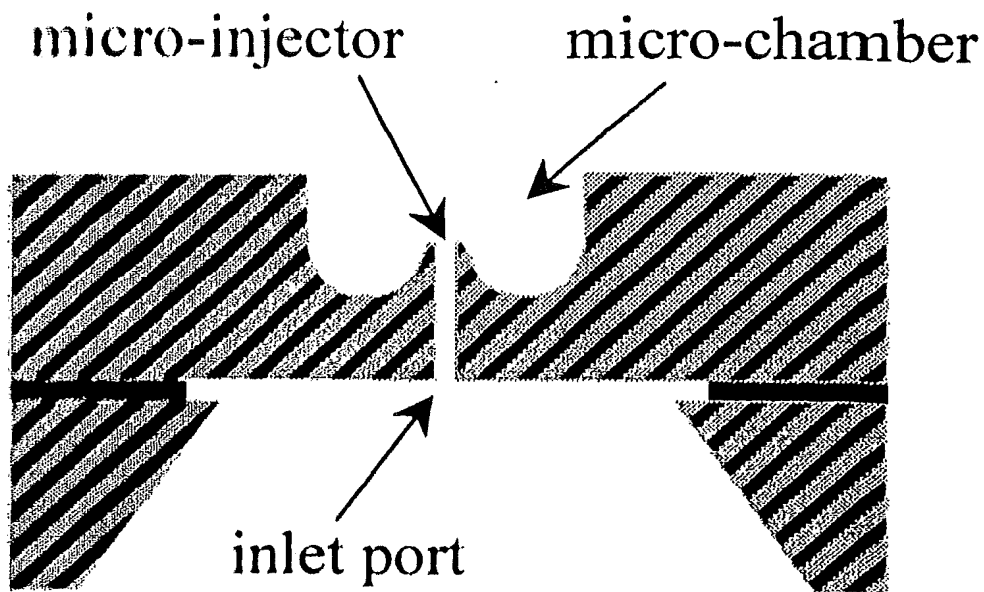

Fig. 2. A representative view of a single injector

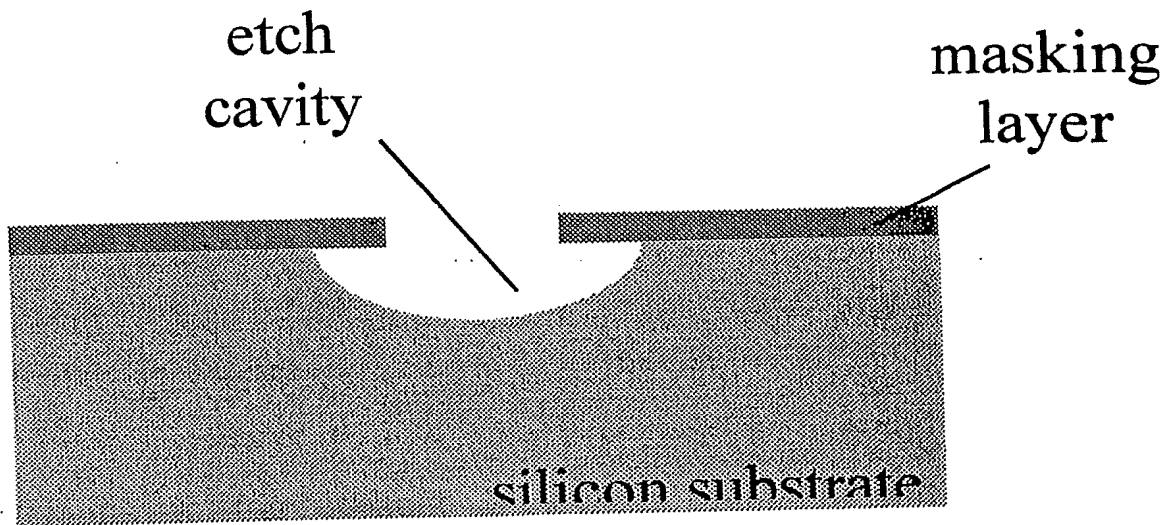

Fig. 3. Cross-sectional view of cavity formation using a masking layer with an isotropic etchant

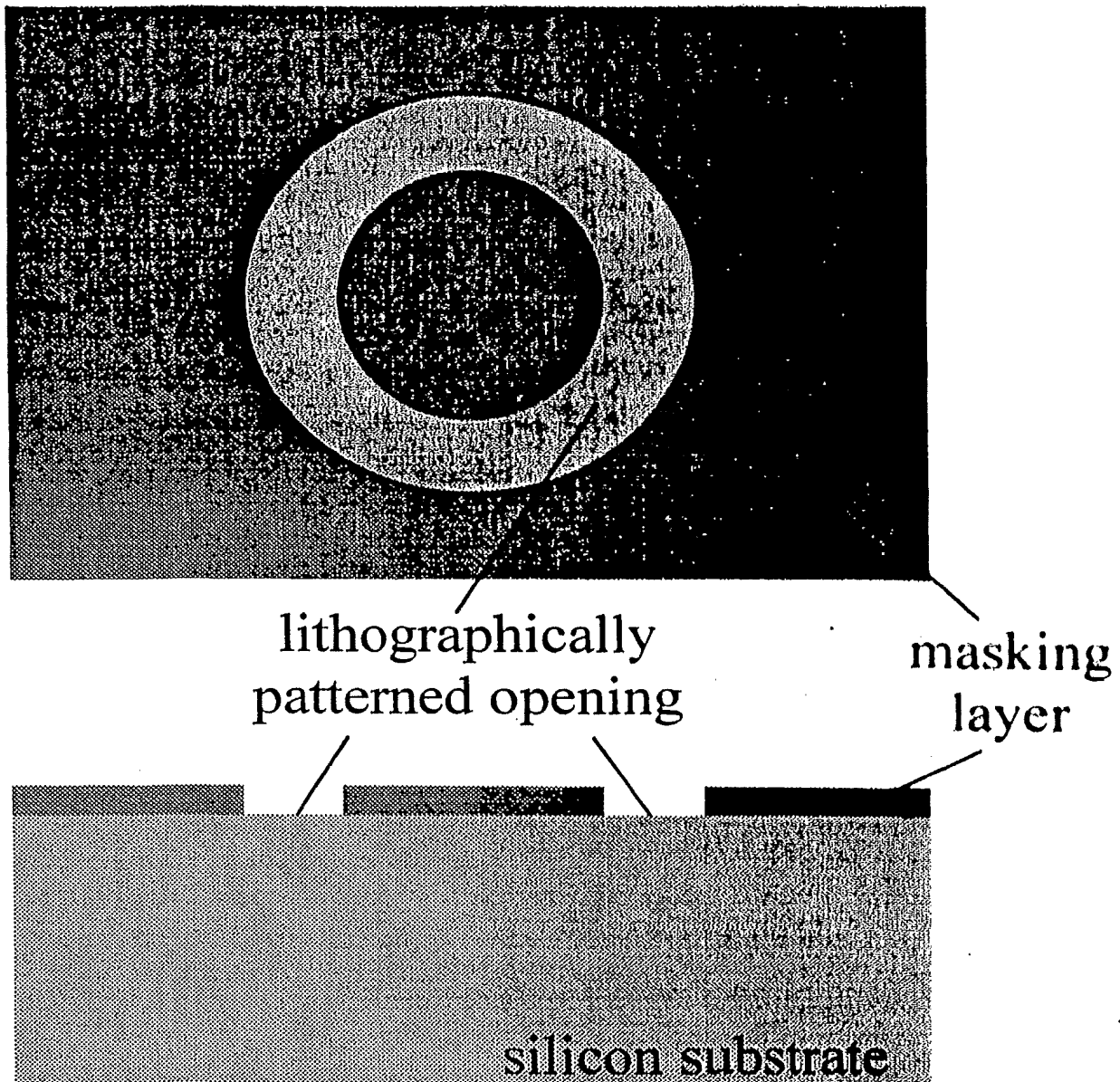

Fig. 4. Top and cross-sectional view of the annulus masking pattern.

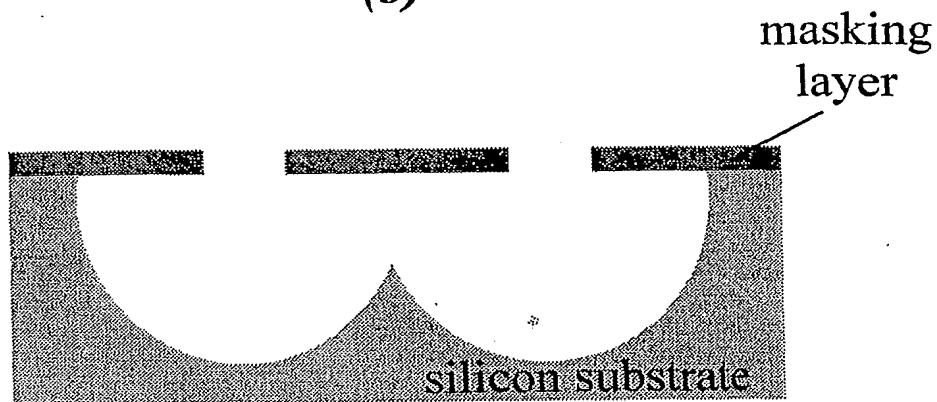
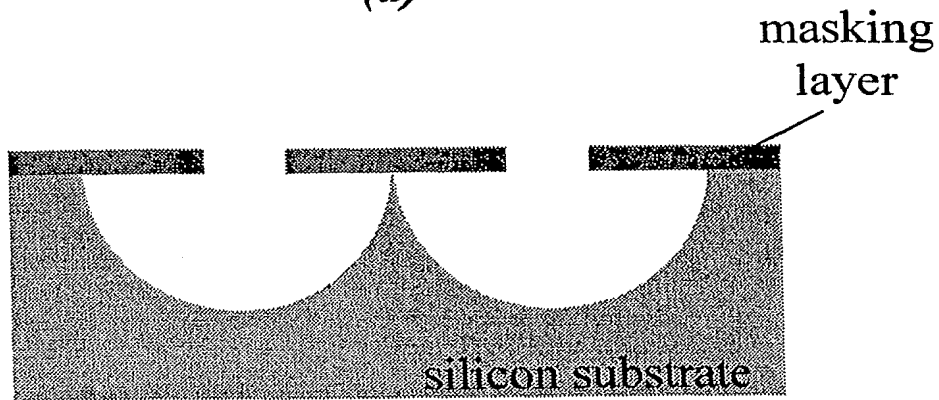
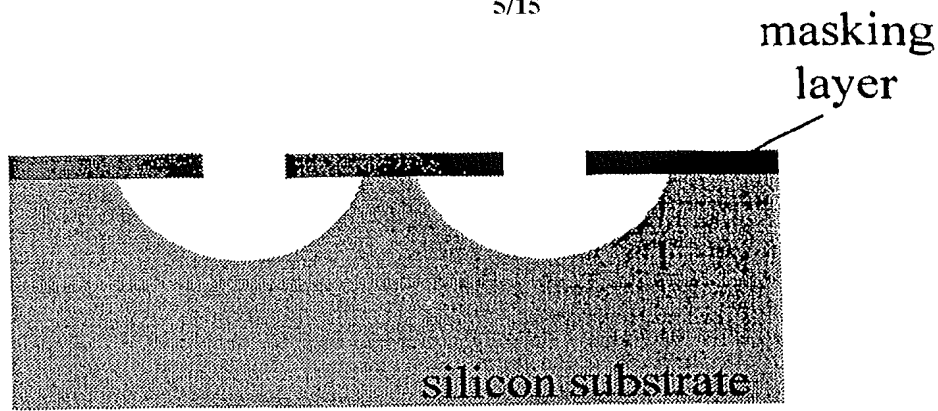
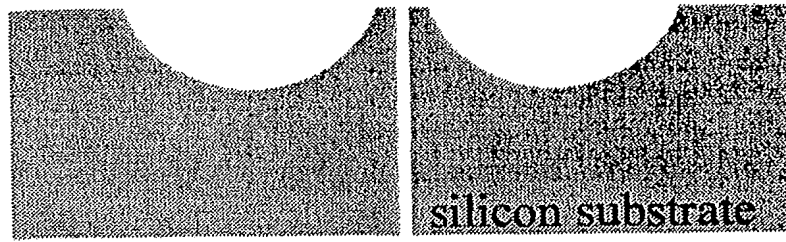
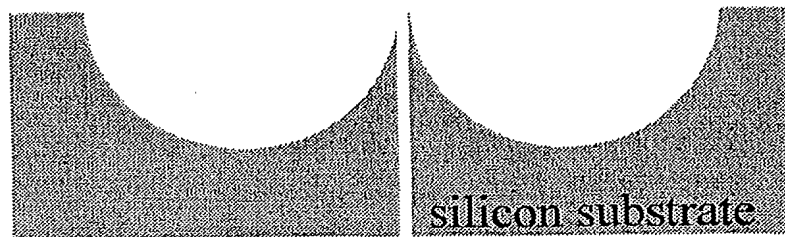

Fig. 5. Cross-sectional views of the etch profile of isotropic etching for varying times.



(a)



(b)



(c)

Fig. 6. *Cross-sectional view of the micro-injector with inlet port*

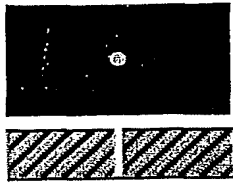

- Silicon Surface Oxidation
- Front/Back-side Lithography
- Deep Dry Etching (DRIE)

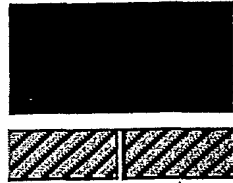
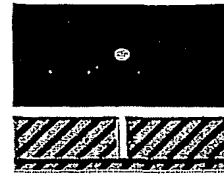

- Deposition of Silicon Oxide

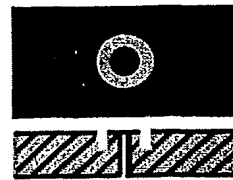
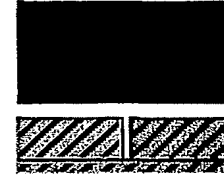

- Wafer Front-side Lithography
- Anisotropic Silicon Dry Etching (RIE)

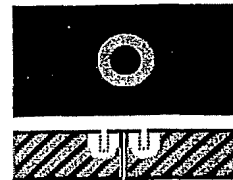
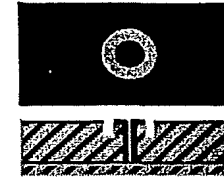

- Silicon Isotropic Dry Etching (RIE)

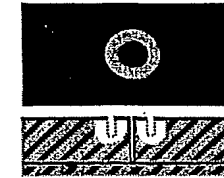

- Backside Wafer Lithography
- Silicon Anisotropic Etching (TMAH)

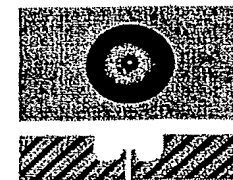
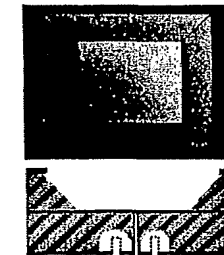

- Silicon Oxide Wet Etching

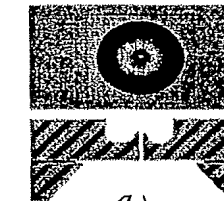

(a)

(b)

Fig. 7. Fabrication process flow for (a) ultra-thin wafer, and (b) SOI wafer. The only difference in the fabrication sequence shown above is in the first step where front-side lithography is done on the SOI wafer, while back-side lithography on the ultra-thin wafer.

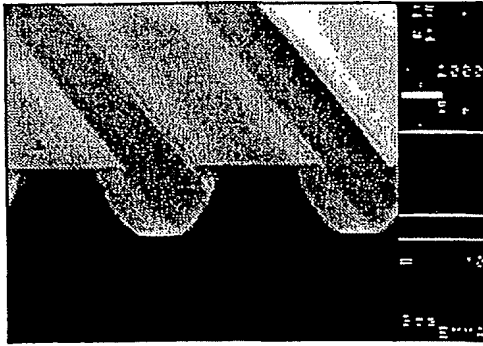

Fig. 8. An SEM of the test structure for determining RIE isotropy

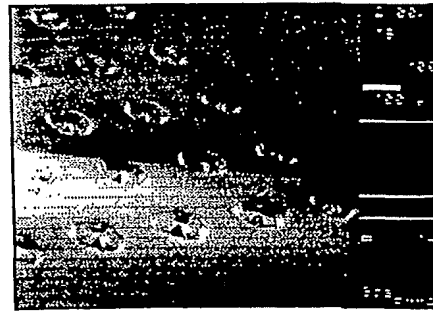

Fig. 9. An SEM of the annuli test structure

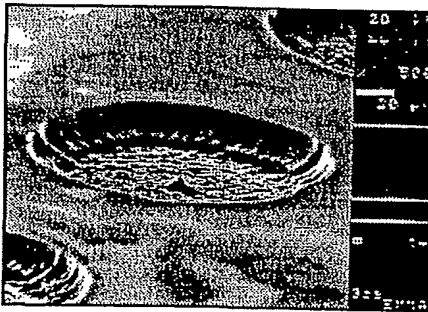

Fig. 10. SEM of one annulus test structure

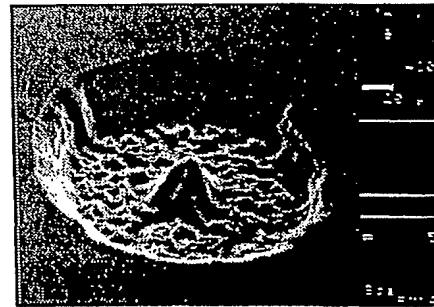

Fig. 11. SEM of an annulus test structure of different dimension

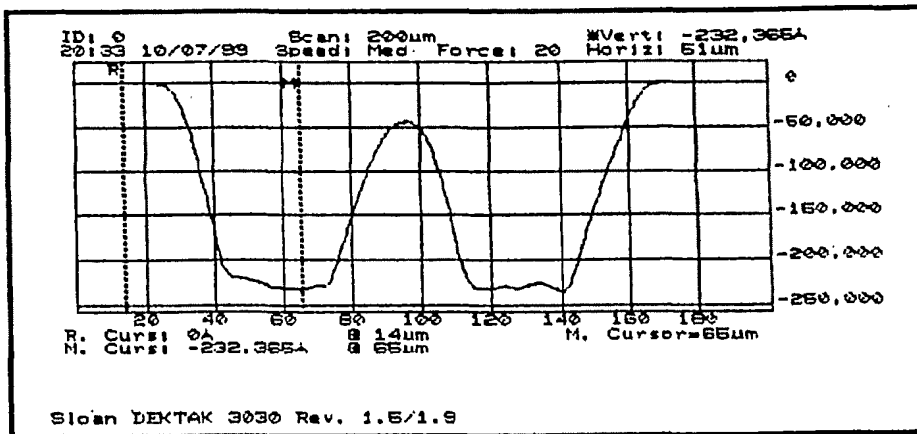
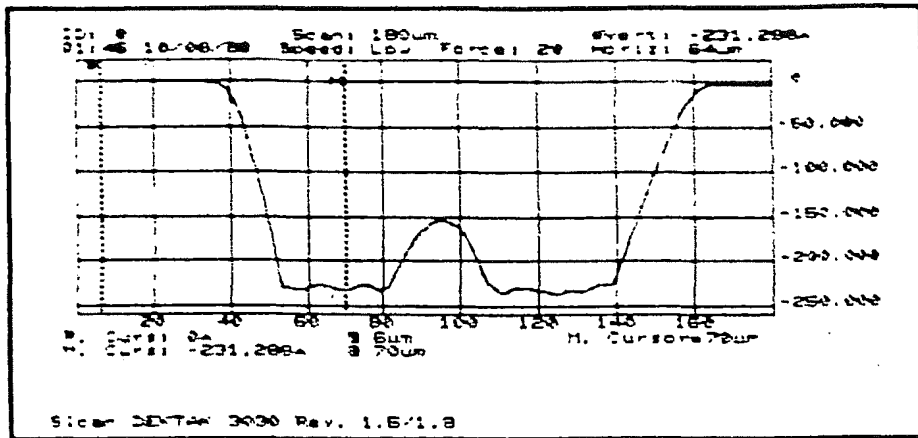
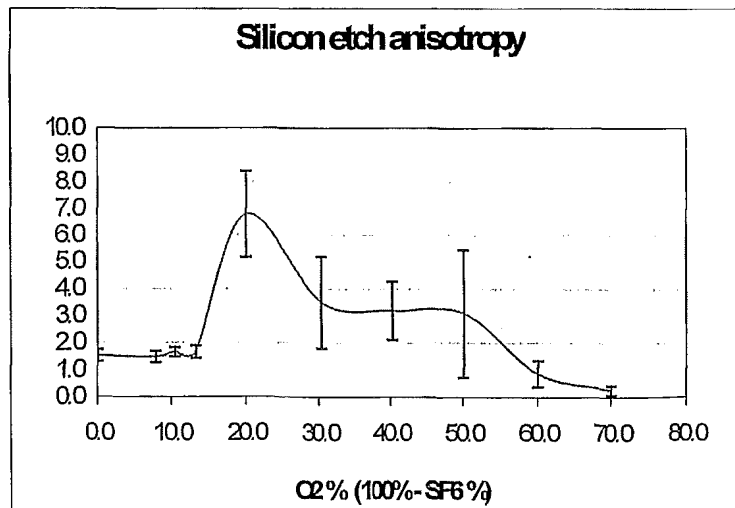
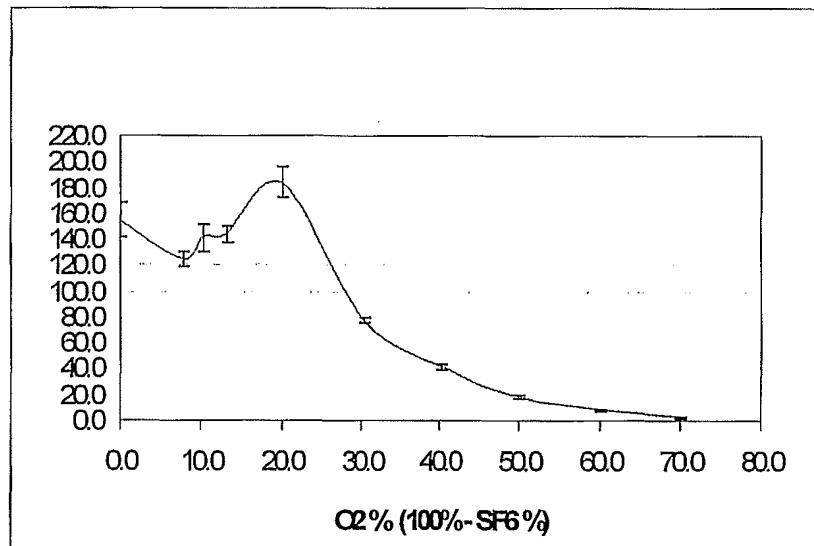
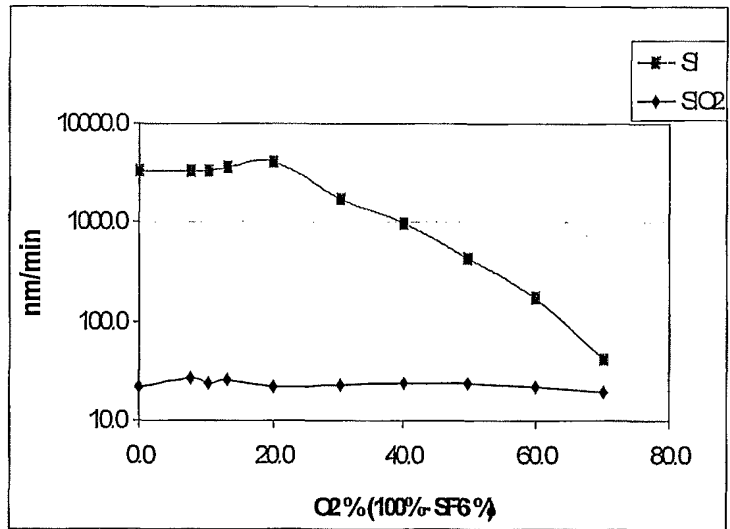
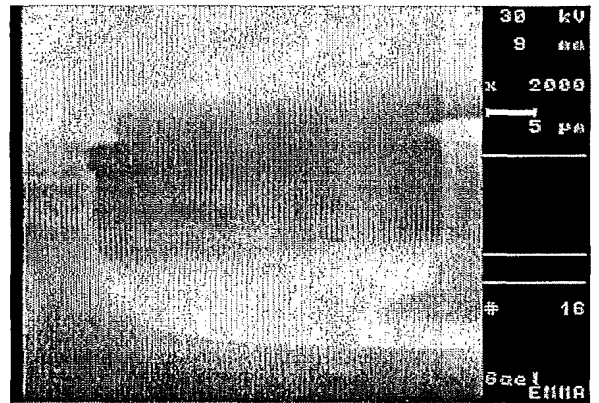
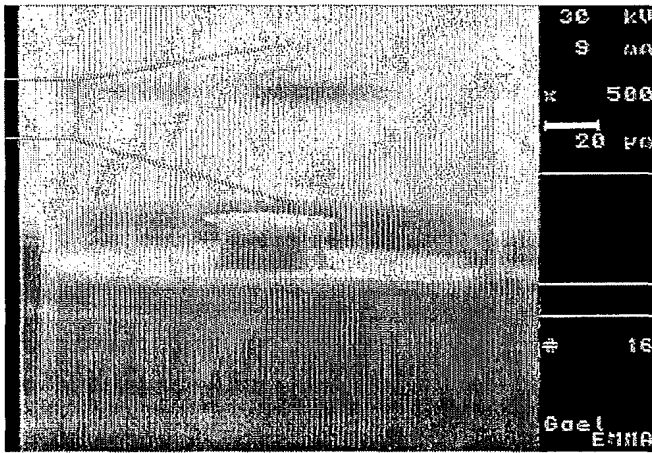
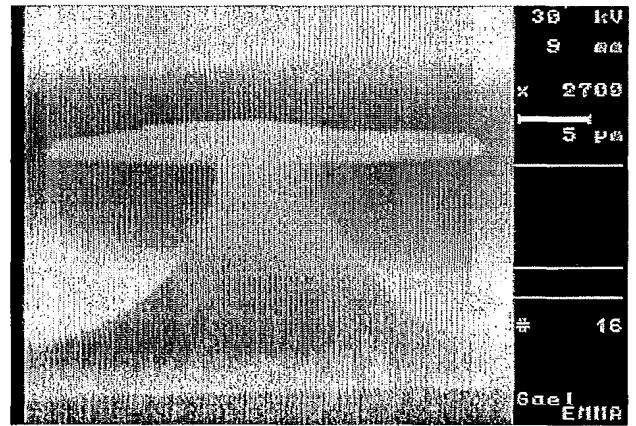
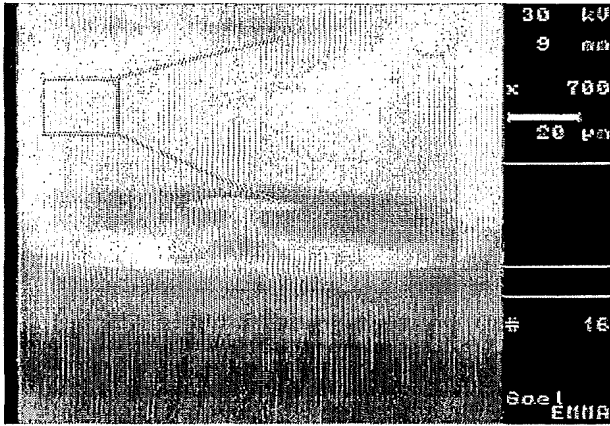

Fig. 12. Surface topography scans for the annuli of (a) Fig. 10 and (b) Fig. 11.

Figs. 13. (a)-(c)



Figs. 14. (a)-(b)



Figs. 15. (a)-(c)

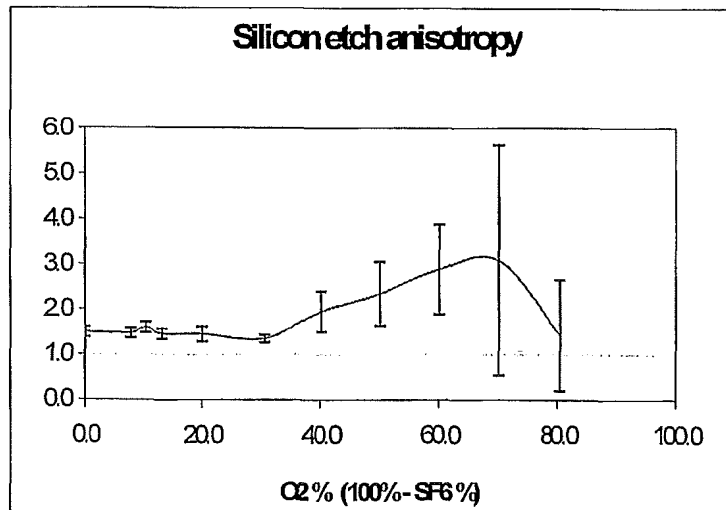
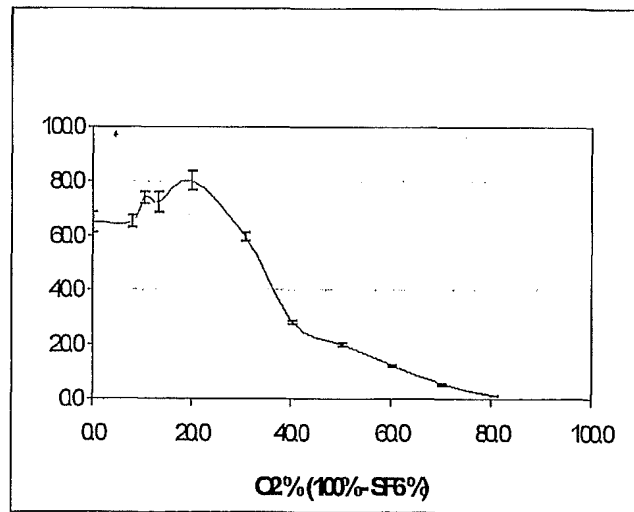
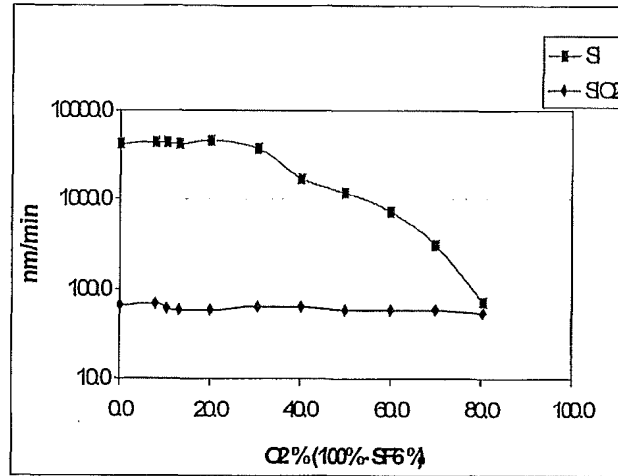

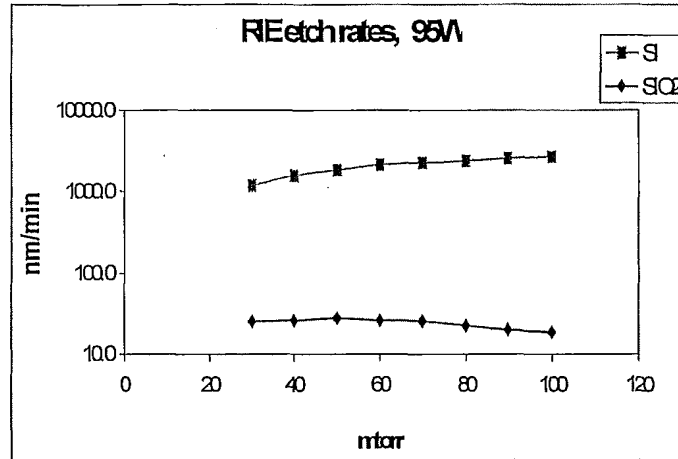

Figs. 16. (a)-(c)

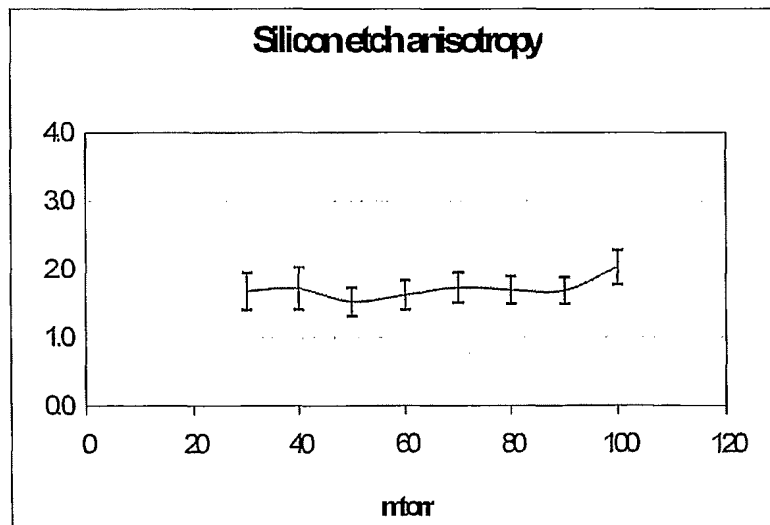
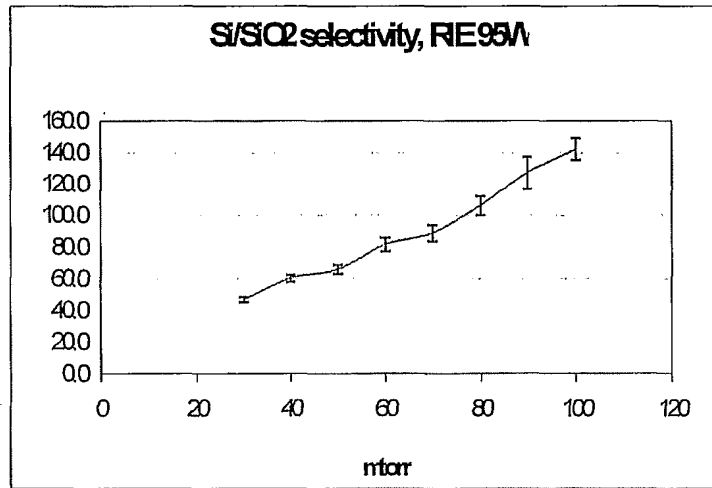

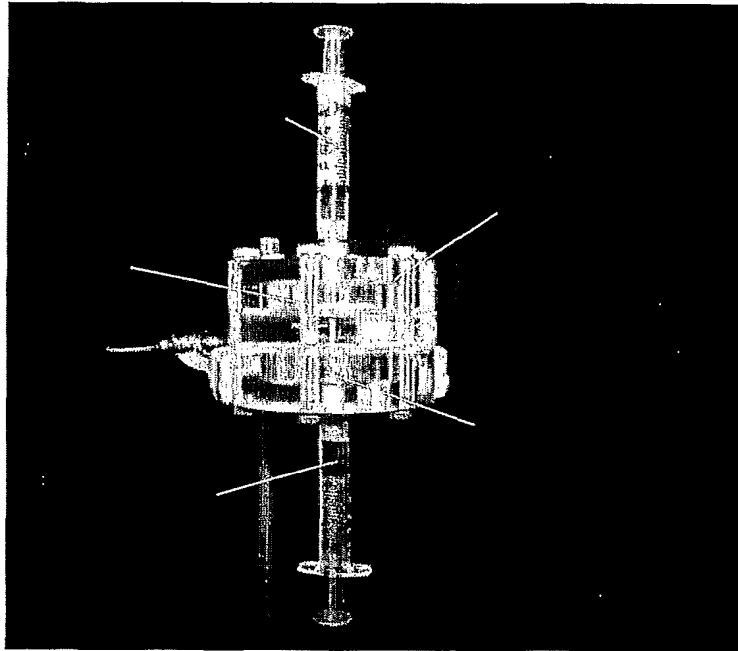

Fig. 17. Plexiglas, water-tight CTM macro-model for pressure analysis

isotropically etched cavity

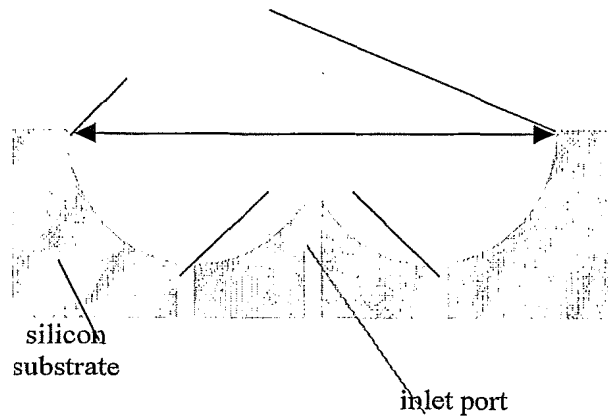

Fig. 18. Cross-section of the μ -injector showing inlet and added venting ports

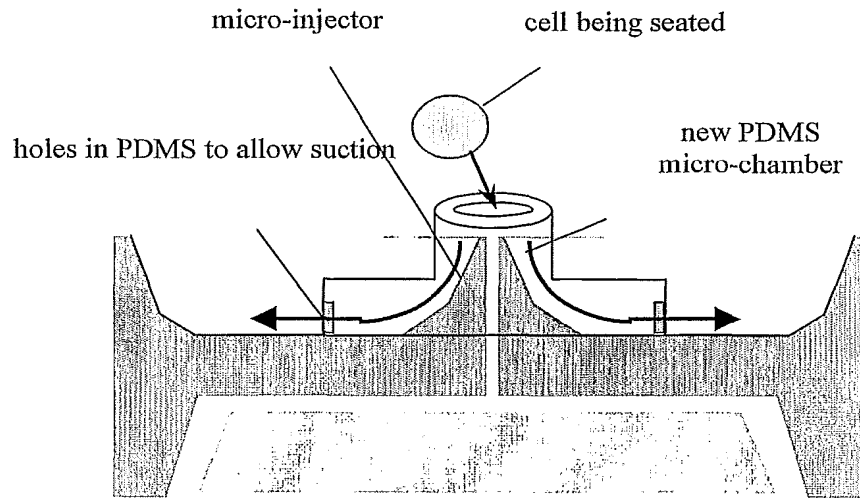

Fig. 19. New design that uses a top PDMS layer, forming the μ -chamber and allowing for fluid venting and suction. The bottom PDMS acts as cavity backfill.

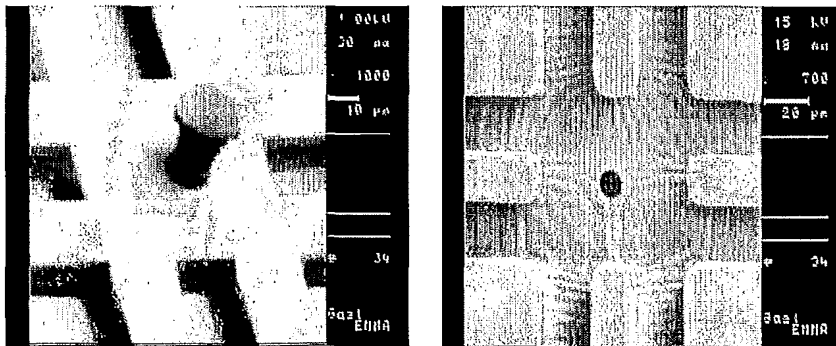
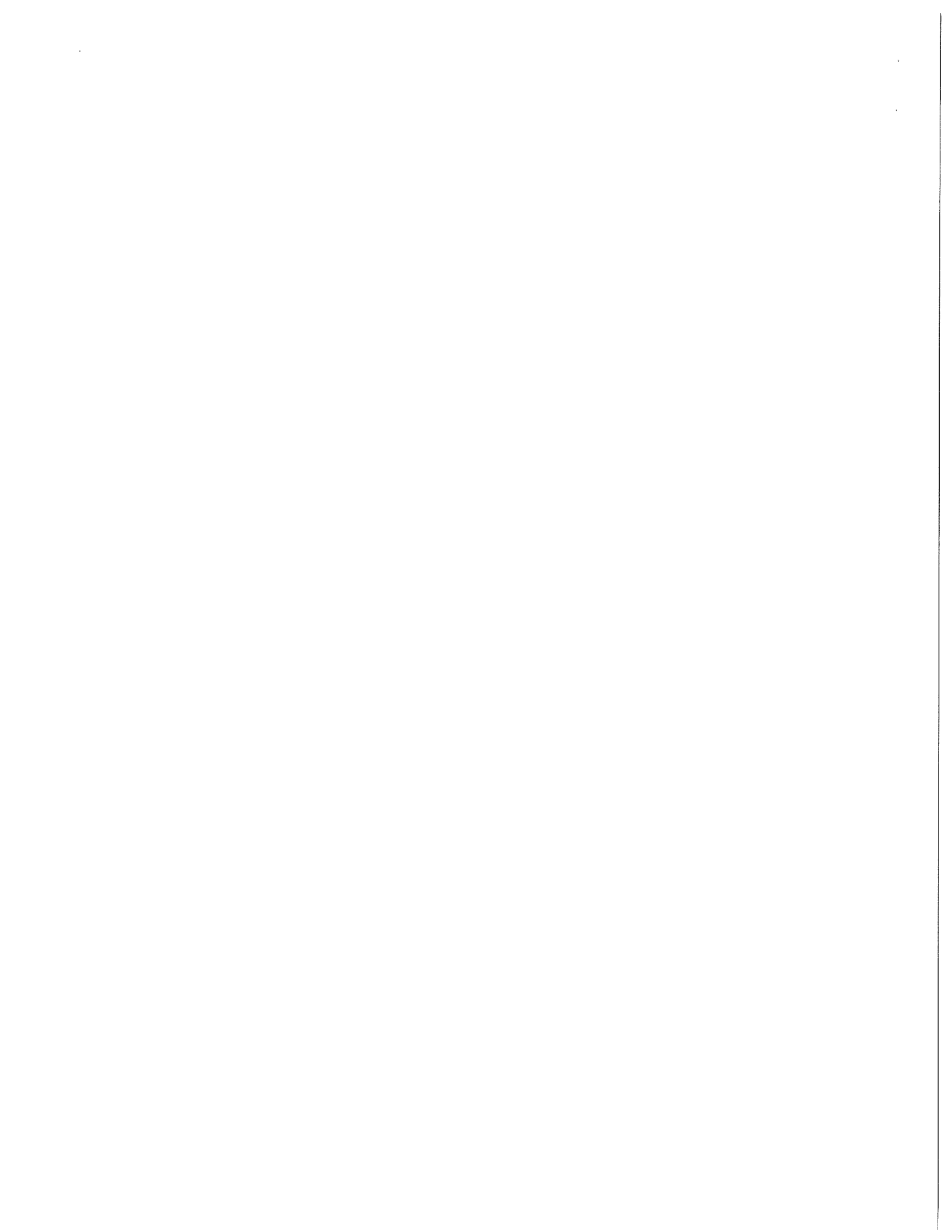

Fig. 20. SEM's of SU-8 mold (left) and the resulting PDMS (right). The center post is 10 μ m in diameter.



(19) World Intellectual Property Organization
International Bureau



(43) International Publication Date
1 August 2002 (01.08.2002)

PCT

(10) International Publication Number
WO 02/058847 A3

(51) International Patent Classification⁷: C12M 3/00

Arlington, VA 22209 (US). **ESRICK, Mark, A.** [US/US]; 2400 41st Street, N.W. Apt. #508, Washington, DC 20007 (US). **CURRIE, John, F.** [CA/US]; 6523 Fallwind Lane, Bethesda, MD 20817 (US).

(21) International Application Number: PCT/US01/44289

(22) International Filing Date:
28 November 2001 (28.11.2001)

(74) Agents: **TESKIN, Robin, L.** et al.; Pillsbury Winthrop LLP, 1600 Tysons Boulevard, McLean, VA 22102 (US).

(25) Filing Language: English

(26) Publication Language: English

(81) Designated States (*national*): AE, AG, AL, AM, AT, AU, AZ, BA, BB, BG, BR, BY, BZ, CA, CH, CN, CO, CR, CU, CZ, DE, DK, DM, DZ, EC, EE, ES, FI, GB, GD, GE, GH, GM, HR, HU, ID, IL, IN, IS, JP, KE, KG, KP, KR, KZ, LC, LK, LR, LS, LT, LU, LV, MA, MD, MG, MK, MN, MW, MX, MZ, NO, NZ, OM, PH, PL, PT, RO, RU, SD, SE, SG, SI, SK, SL, TJ, TM, TR, TT, TZ, UA, UG, US, UZ, VN, YU, ZA, ZM, ZW.

(30) Priority Data:
60/253,094 28 November 2000 (28.11.2000) US

(71) Applicant (*for all designated States except US*):
GEORGETOWN UNIVERSITY [US/US]; 3900 Reservoir Road, N.W., Washington, DC 20007 (US).

(72) Inventors; and

(84) Designated States (*regional*): ARIPO patent (GH, GM, KE, LS, MW, MZ, SD, SL, SZ, TZ, UG, ZM, ZW), Eurasian patent (AM, AZ, BY, KG, KZ, MD, RU, TJ, TM),

(75) Inventors/Applicants (*for US only*): **PARANJAPE, Makarand** [CA/US]; 1530 N. Key Boulevard, Apt. 503,

[Continued on next page]

(54) Title: CELL TRANSFORMATION USING A SINGLE CHIP SILICON MICROFABRICATED ARRAY INCORPORATING INTEGRATED MICRO-PIERCING INJECTORS

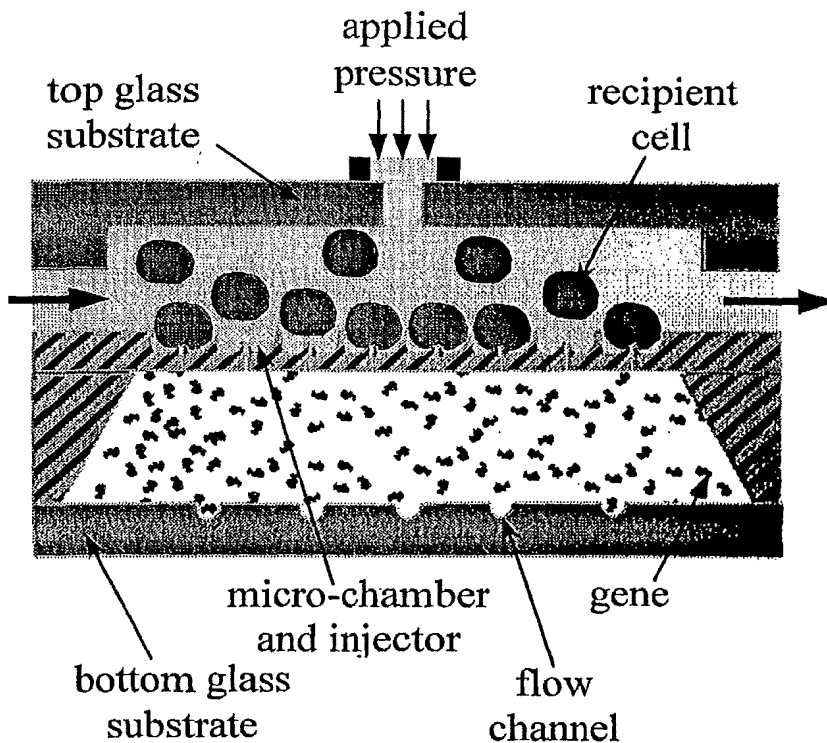

(57) Abstract: The present invention provides an improved methodology for the introduction of specific molecules into cells, or the removal of material from cells, over the current state of the art. In particular, the invention provides an efficient means for these procedures to be undertaken on a high throughput level using minimally skilled expertise and handling by providing a microfabricated silicon array substrate having a simplified device fabrication strategy, whereby a single device component performs the transformation process rendering a more durable and robust device.

Cell Transformation Microdevice

WO 02/058847 A3



European patent (AT, BE, CH, CY, DE, DK, ES, FI, FR, GB, GR, IE, IT, LU, MC, NL, PT, SE, TR), OAPI patent (BF, BJ, CF, CG, CI, CM, GA, GN, GQ, GW, ML, MR, NE, SN, TD, TG).

(88) Date of publication of the international search report:
10 April 2003

Published:

— with international search report

For two-letter codes and other abbreviations, refer to the "Guidance Notes on Codes and Abbreviations" appearing at the beginning of each regular issue of the PCT Gazette.

INTERNATIONAL SEARCH REPORT

International Application No
PCT/US 01/44289

A. CLASSIFICATION OF SUBJECT MATTER IPC 7 C12M3/00		
According to International Patent Classification (IPC) or to both national classification and IPC		
B. FIELDS SEARCHED		
Minimum documentation searched (classification system followed by classification symbols) IPC 7 C12M		
Documentation searched other than minimum documentation to the extent that such documents are included in the fields searched		
Electronic data base consulted during the international search (name of data base and, where practical, search terms used) EPO-Internal, WPI Data, PAJ		
C. DOCUMENTS CONSIDERED TO BE RELEVANT		
Category *	Citation of document, with indication, where appropriate, of the relevant passages	Relevant to claim No.
P, X	WO 01 19978 A (CORNELL RES FOUNDATION INC) 22 March 2001 (2001-03-22) claims; figures 3-5 ---	1-16, 18-20, 22-38, 41
X	WO 00 20554 A (SHAW JOHN EDWARD ANDREW ;BRENNAN DAVID (GB); DODGSON JOHN (GB); ZE) 13 April 2000 (2000-04-13) claims; figures ---	41-48, 50
A	US 5 183 744 A (KAWAMURA YOSHIO ET AL) 2 February 1993 (1993-02-02) ---	
A	DE 198 41 337 C (MICRONAS INTERMETALL GMBH) 23 September 1999 (1999-09-23) ---	
A	US 5 262 128 A (BROWNSTEIN MICHAEL J ET AL) 16 November 1993 (1993-11-16) ---	
	-/--	
<input checked="" type="checkbox"/> Further documents are listed in the continuation of box C. <input checked="" type="checkbox"/> Patent family members are listed in annex.		
* Special categories of cited documents :		
A document defining the general state of the art which is not considered to be of particular relevance *E* earlier document but published on or after the international filing date *L* document which may throw doubts on priority claim(s) or which is cited to establish the publication date of another citation or other special reason (as specified) *O* document referring to an oral disclosure, use, exhibition or other means *P* document published prior to the international filing date but later than the priority date claimed *T* later document published after the international filing date or priority date and not in conflict with the application but cited to understand the principle or theory underlying the invention *X* document of particular relevance; the claimed invention cannot be considered novel or cannot be considered to involve an inventive step when the document is taken alone *Y* document of particular relevance; the claimed invention cannot be considered to involve an inventive step when the document is combined with one or more other such documents, such combination being obvious to a person skilled in the art. *&* document member of the same patent family		
Date of the actual completion of the international search 5 August 2002		Date of mailing of the international search report 13/08/2002
Name and mailing address of the ISA European Patent Office, P.B. 5818 Patentlaan 2 NL - 2280 HV Rijswijk Tel. (+31-70) 340-2040, Tx. 31 651 epo nl, Fax: (+31-70) 340-3016		Authorized officer Coucke, A

INTERNATIONAL SEARCH REPORT

Intel International Application No

PCT/US 01/44289

C.(Continuation) DOCUMENTS CONSIDERED TO BE RELEVANT		
Category *	Citation of document, with indication, where appropriate, of the relevant passages	Relevant to claim No.
X	<p>CHUN K ET AL: "An array of hollow microcapillaries for the controlled injection of genetic materials into animal/plant cells"</p> <p>MICRO ELECTRO MECHANICAL SYSTEMS, 1999. MEMS '99. TWELFTH IEEE INTERNATIONAL CONFERENCE ON ORLANDO, FL, USA 17-21 JAN. 1999, PISCATAWAY, NJ, USA, IEEE, US, 17 January 1999 (1999-01-17), pages 406-411, XP010321695 ISBN: 0-7803-5194-0 page 407</p> <p style="text-align: center;">-----</p>	41-45

INTERNATIONAL SEARCH REPORT
 Information on patent family members

Intel International Application No
 PCT/US 01/44289

Patent document cited in search report		Publication date	Patent family member(s)	Publication date
WO 0119978	A	22-03-2001	AU 7578900 A	17-04-2001
			WO 0119978 A1	22-03-2001
			US 6383813 B1	07-05-2002
WO 0020554	A	13-04-2000	AU 6216199 A	26-04-2000
			EP 1124939 A1	22-08-2001
			WO 0020554 A1	13-04-2000
US 5183744	A	02-02-1993	JP 2117380 A	01-05-1990
			JP 2747304 B2	06-05-1998
			JP 2131569 A	21-05-1990
			JP 2829005 B2	25-11-1998
DE 19841337	C	23-09-1999	DE 19841337 C1	23-09-1999
			EP 0962524 A1	08-12-1999
			JP 11346764 A	21-12-1999
			DE 19827957 A1	09-12-1999
			EP 0960933 A1	01-12-1999
			JP 11346794 A	21-12-1999
			US 6368851 B1	09-04-2002
US 5262128	A	16-11-1993	AU 6640190 A	16-05-1991
			EP 0497885 A1	12-08-1992
			WO 9105519 A1	02-05-1991

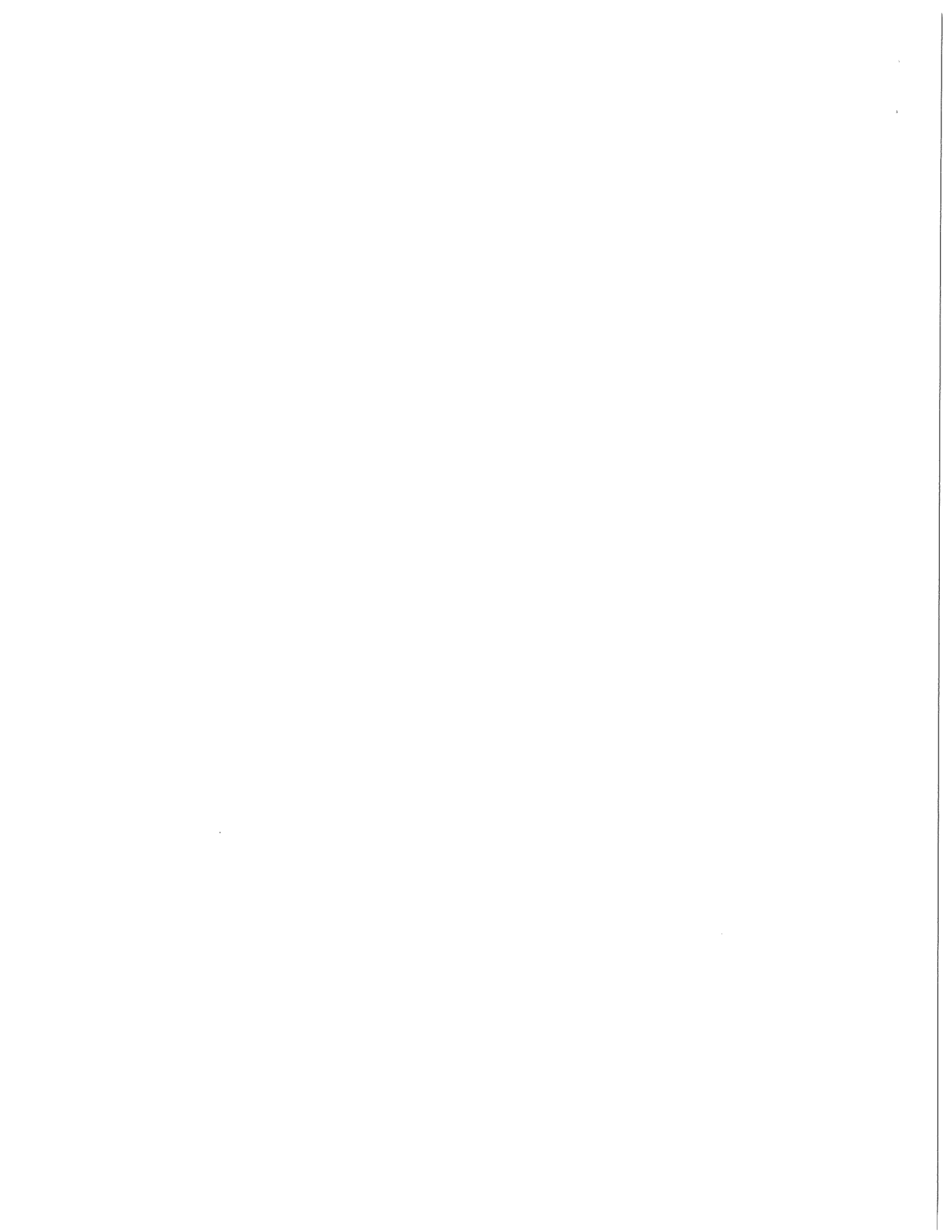

CORRECTED VERSION

(19) World Intellectual Property Organization
International Bureau



(43) International Publication Date
1 August 2002 (01.08.2002)

PCT

(10) International Publication Number
WO 02/058847 A3

(51) International Patent Classification⁷: C12M 3/00

Arlington, VA 22209 (US). **ESRICK, Mark, A.** [US/US]; 2400 41st Street, N.W. Apt. #508, Washington, DC 20007 (US). **CURRIE, John, F.** [CA/US]; 6523 Fallwind Lane, Bethesda, MD 20817 (US).

(21) International Application Number: PCT/US01/44289

(22) International Filing Date:
28 November 2001 (28.11.2001)

(74) Agents: **TESKIN, Robin, L.** et al.; Pillsbury Winthrop LLP, 1600 Tysons Boulevard, McLean, VA 22102 (US).

(25) Filing Language: English

(81) Designated States (*national*): AE, AG, AL, AM, AT, AU, AZ, BA, BB, BG, BR, BY, BZ, CA, CH, CN, CO, CR, CU, CZ, DE, DK, DM, DZ, EC, EE, ES, FI, GB, GD, GE, GH, GM, HR, HU, ID, IL, IN, IS, JP, KE, KG, KP, KR, KZ, LC, LK, LR, LS, LT, LU, LV, MA, MD, MG, MK, MN, MW, MX, MZ, NO, NZ, OM, PH, PL, PT, RO, RU, SD, SE, SG, SI, SK, SL, TJ, TM, TR, TT, TZ, UA, UG, US, UZ, VN, YU, ZA, ZM, ZW.

(26) Publication Language: English

(30) Priority Data:
60/253,094 28 November 2000 (28.11.2000) US

(71) Applicant (*for all designated States except US*):
GEORGETOWN UNIVERSITY [US/US]; 3900 Reservoir Road, N.W., Washington, DC 20007 (US).

(84) Designated States (*regional*): ARIPO patent (GH, GM, KE, LS, MW, MZ, SD, SL, SZ, TZ, UG, ZM, ZW), Eurasian patent (AM, AZ, BY, KG, KZ, MD, RU, TJ, TM), European patent (AT, BE, CH, CY, DE, DK, ES, FI, FR, GB, GR, IE, IT, LU, MC, NL, PT, SE, TR), OAPI patent

(72) Inventors; and
(75) Inventors/Applicants (*for US only*): **PARANJAPE, Makarand** [CA/US]; 1530 N. Key Boulevard, Apt. 503,

[Continued on next page]

(54) Title: CELL TRANSFORMATION USING A SINGLE CHIP SILICON MICROFABRICATED ARRAY INCORPORATING INTEGRATED MICRO-PIERCING INJECTORS

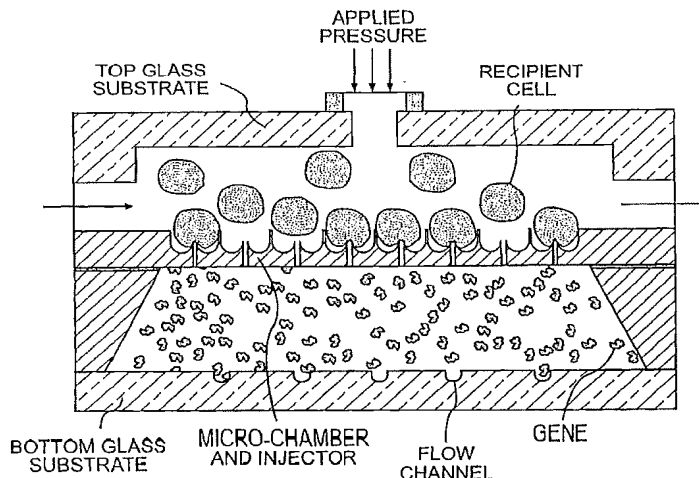

CELL TRANSFORMATION MICRODEVICE

(57) Abstract: The present invention provides an improved methodology for the introduction of specific molecules into cells, or the removal of material from cells, over the current state of the art. In particular, the invention provides an efficient means for these procedures to be undertaken on a high throughput level using minimally skilled expertise and handling by providing a microfabricated silicon array substrate having a simplified device fabrication strategy, whereby a single device component performs the transformation process rendering a more durable and robust device.



WO 02/058847 A3



(BF, BJ, CF, CG, CI, CM, GA, GN, GQ, GW, ML, MR, NE, SN, TD, TG).

(48) Date of publication of this corrected version:

30 May 2003

Published:

— *with international search report*

(15) Information about Correction:

see PCT Gazette No. 22/2003 of 30 May 2003, Section II

(88) Date of publication of the international search report:

10 April 2003

For two-letter codes and other abbreviations, refer to the "Guidance Notes on Codes and Abbreviations" appearing at the beginning of each regular issue of the PCT Gazette.

**Cell Transformation Using a Single Chip Silicon
Microfabricated Array Incorporating Integrated
Micro-Piercing Injectors**

[0001] This application claims the benefit of U.S. Provisional Application No. 60/253,094, filed on November 28, 2000, the entire contents of which are incorporated herein by reference thereto.

Field of Invention

[0002] This invention relates to methods for transforming or transfecting a plurality of individual cells with nucleic acids, small drug doses or other molecules of interest, and particularly to microfabricated devices for performing such transformations and other minute operations on a high throughput level.

Background of Invention

[0003] Cell transformation is a procedure often used by researchers in genetics, cell biology, and molecular biology that results from the introduction of specific molecules, such as DNA, RNA, and low-dose drugs into the nucleus or cytoplasm of a recipient cell. Transformation allows for the identification of novel genes, the isolation of genetically modified cells, and the screening of potential drugs, and much effort has been focused on ensuring that transformation efficiencies are optimized in order to increase the retrieval of transformed cells and/or decrease the number of cells which must be treated.

[0004] Technologies associated with improving transformation efficiency and cell viability following transformation have seen extensive research and development. For instance, classical methods include chemical means whereby cells are treated with either calcium phosphate/DNA or DEAE-DeXtran/DNA in order to integrate an isolated gene into the nuclear genome (transfection) of mammalian cells. Although calcium phosphate transformation is relatively inexpensive and can accommodate high concentrations of DNA, transfection efficiency is often less than 10% and is typically associated with a low rate of viability. Likewise, while DEAE-DeXtran is advantageous in that it typically requires less DNA than other methods and is applicable to many different types of cells, it also suffers from low transfection efficiency and high toxicity.

[0005] Biological means of transforming cells have also been developed. For instance, replication-deficient recombinant retroviruses may be used to accurately integrate a single copy of a gene into the genome of a target cell. However, such vectors cannot infect non-dividing or fully differentiated cells, e.g., neurons or hepatic cells, unless they are stimulated to divide, and can only accommodate genes and other nucleic acids that are less than 8 kilobases long. Furthermore, purification and concentration of retroviruses without loss of infectivity is difficult, and stable transfectants which exhibit long-term expression of transfected genes are rare. Recombinant adenoviruses are advantageous in that they infect non-dividing cells and may be concentrated without significant loss of infectivity. However, these viruses can only incorporate genes which are less than 5 kilobases, and their genome does not integrate into the target cell's genome but rather remains episomal, resulting in transient gene expression.

[0006] Physical methods of transformation have also been developed. Electroporation employs an electric pulse applied to a cell/DNA suspension, and is believed to induce local areas of reversible membrane breakdown thereby creating pores through which the DNA enters the cell. Although electroporation is effective for a large number of different cell types and is relatively reproducible and easy to perform, it requires more cells and DNA than chemical methods and there is typically a large variation in optimizing parameters between different cell lines, e.g., field strength, pulse duration. Moreover, efficiency may vary depending on the cell type, and the non-physiological conditions required in the medium limit cell viability.

[0007] Particle bombardment has also been used, whereby DNA coated tungsten or gold particles are accelerated into cells. However, this technique usually yields only transient gene expression. Liposomal delivery provides the advantages of higher efficiency and relatively low cell toxicity, and is amenable to the transformation of more molecules than just DNA, including RNA, synthetic oligonucleotides, proteins and viruses. However, liposomes are relatively costly, practically precluding their use for large scale transfections. Microinjection using a fine tipped pipet may also be used to introduce DNA, RNA, antibodies, peptides and oligonucleotides into cells, and has proved successful with large frog eggs, mammalian embryos, plant protoplasts and tissues. However, this technique is extremely labor intensive in that only one cell is injected at a time. See Nikitin et al, U.S. Patent 4,619,899.

[0008] More recently, silicon-based micromachined systems have been developed which eliminate some of the problems associated with the above methods. For instance, electroporation may now be performed on the micro-level whereby cells are trapped in microchambers fitted with electrodes, electroporated, and exogenous genetic material is diffused through the resultant pores into the cells. While there is the potential that all cells can be transfected since all are treated identically, the amount of exogenous material that enters the cells can not be controlled. Furthermore, device fabrication is not straightforward. See Le Pioufle et al, Attachment of Cells on Microsystems: Application to the Gene Transfection, Transducers '99, 768-71, Sendai, Japan.

[0009] Hollow micro-capillaries have also been designed which permit controlled injection of DNA and other materials into cells, whereby the hollow micro-capillaries are inserted into individual cells trapped in microchambers within the surface of a silicon wafer and the material of interest is injected. See McAllister et al, Three-Dimensional Hollow Micro-Needle and Micro-Tube Arrays, Transducers '99, 1098-1101, Sendai, Japan; see also Chun et al, An Array of Hollow Microcapillaries for the Controlled Injection of Genetic Materials into Animal/Plant Cells, 12th IEEE Int'l Conf. on Microelectromechanical Systems, Orlando, Fl, Jan. 1999, pp. 406-411. Microprobes or short points covered with genetic material have also been used to pierce cells and introduce the genetic material into an array of individual cells. Although such microfabricated devices are advantageous in the control they provide over transfection conditions, the ease of operation, and the level of transfection efficiency achieved, the apparatus requires two separate devices (micro-capillary array for injection and micro-chamber array for holding the cells). Such a system inherently possesses critical alignment problems resulting in variations in injection efficiency, and typically requires a further device for positioning the first two devices accurately with respect to one another. See Leighton and Brownstein, U.S. Patent 5,262,128. Moreover, the micro-capillary needles are fragile and therefore not very durable, and require a complex and specialized fabrication process.

[0010] Thus, there is a need for cell transformation systems which result in high efficiency, e.g., high throughput, and low cell death, and which avoid the high cost and labor intensive expenditures seen in the prior art. Further, in terms of microdevices, more durable designs are needed which do not require complicated fabrication processes.

Summary of Invention

[0011] The present invention overcomes the deficiencies of the prior art by providing a cost effective, durable apparatus that enables essentially simultaneous transformation (into the cytoplasm) or transfection (into the nucleus) of a plurality of cells with a wide variety of molecules and substances. More particularly, the present invention provides a silicon wafer containing an array of micro-cavities fitted with hollow needle like protrusions allowing individual cells to be simultaneously trapped and pierced for material injection or extraction.

[0012] The micro-device of the present invention is advantageous over devices of the prior art in that a large number of cells may be easily transformed or transfected in a single step with minimal loss of cell viability, requiring minimal expertise and handling at an optimum cost. In particular, because the microdevices of the present integrate micro-piercing injectors into the design of the micro-chambers, the present devices are simpler to make, e.g., are made using standard silicon processing and micromachining technologies, and are more durable than the silicon chip injection units of the prior art. Further, the micro-devices of the present invention are one-piece injection modules that require no critical alignment procedures.

[0013] Also included in the invention are methods of transforming and transfecting a plurality of cells with a variety of molecules and substances using the microdevices of the present invention, and also methods of fusing different types of cells using the disclosed devices. Cell transformation, transfection and fusion may be performed in a parallel process with the potential for high throughput using multi-level stacked elements. Transformed and transfected cells produced by the methods of the invention are also included, as are a variety of supplementary devices and connections which facilitate collection and analyses of the transformed cells.

Brief Description of the Figures

[0014] Figure 1. Diagram of a preferred cell transformation microdevice of the present invention.

[0015] Figure 2. Enlarged view of a single micro-piercing injector.

[0016] Figure 3. Cross-sectional view of cavity formation using a masking layer with an isotropic etchant.

[0017] Figure 4. Top and cross-sectional view of the annulus masking pattern.

- [0018] Figure 5. Cross-sectional views of the etch profile of isotropic etching for varying times.
- [0019] Figure 6. Cross-sectional view of the micro-injector with inlet port.
- [0020] Figure 7. Fabrication process flow for (a) ultra-thin wafer, and (b) SOI wafer. The only difference in the fabrication sequence shown above is in the first step where front-side lithography is done on the SOI wafer, while back-side lithography on the ultra-thin wafer.
- [0021] Figure 8. An SEM of the test structure for determining RIE isotropy.
- [0022] Figure 9. An SEM of the annuli test structure.
- [0023] Figure 10. SEM of one annulus test structure.
- [0024] Figure 11. SEM of an annulus test structure of different dimension.
- [0025] Figure 12. Surface topography scans for the annuli of (a) Fig. 10 and (b) Fig. 11.
- [0026] Figure 13. Results of trial at 95/0 W with varied percentage O₂ (a) RIE etch rate; (b) Si/SiO₂ selectivity; and (c) Silicon etch anisotropy.
- [0027] Figure 14. SEM's illustrating the anisotropy and etch profiles for the trial of Figure 13 using (a) 10% O₂ and (b) 20% O₂.
- [0028] Figure 15. Results of trial at 205/5 W with varied percentage O₂ (a) RIE etch rate; (b) Si/SiO₂ selectivity; and (c) Silicon etch anisotropy.
- [0029] Figure 16. Results of trial at 95/0 W with percentage O₂ fixed at 10% (a) RIE etch rate; (b) Si/SiO₂ selectivity; and (c) Silicon etch anisotropy.
- [0030] Figure 17. Plexiglass, water tight CTM macro-model for pressure analysis used in conjunction with one embodiment of the invention.
- [0031] Figure 18. Cross-section of micro-injector with inlet and venting ports in accordance with a preferred embodiment of the invention.
- [0032] Figure 19. Device according to a preferred embodiment of the invention using polydimethylsiloxane silicone rubber (PDMS).
- [0033] Figure 20. SEM's of (a) SU-8 mold and (b) PDMS layer made therefrom.

Detailed Description of the Invention

[0034] In one aspect, the present invention encompasses microfabricated array/injection devices for transforming simultaneously a plurality of cells. A preferred microdevice structure is based on a single chip module containing a large array of microchambers or micro-wells in a silica-based or silicon substrate that house

recipient cells to be transformed (Fig. 1). Inlet ports located at the bottom of each microchamber are integrated into the device in such a way as to simultaneously render micro-piercing injectors during micro-chamber fabrication (Fig. 2). The silicon structure is bonded with a capping substrate on the top in order to introduce recipient cells into the micro-chambers and hold them in place, preferably by the application of hydrostatic pressure, and also with a bottom substrate that contains micro-fluidic channels for biological and molecular component transport (Fig. 1).

[0035] Initially, the cells are allowed to settle into the bottom of each micro-chamber, and when all cavities are filled, hydrostatic pressure is applied from above to trap and hold them in place. During the entrapment procedure, the cell membrane is perforated mechanically by the micro-piercing structures. The inlet ports act as micro-injectors through which biological material or molecules are introduced into the cell using positive pressure applied beneath the micro-injector array. This pressure is applied shortly after the trapping hydrostatic pressure in order to prevent the escape of cell cytoplasm through the perforation.

[0036] More specifically, the present invention encompasses a microdevice for introducing molecules or substances into a plurality of cells, comprising (a) a single microfabricated array substrate having a plurality of individual microchambers, wherein each microchamber holds at least one cell and incorporates an integrated micro-piercing injector; (b) a top planar substrate for entrapping individual cells in microchambers; and (c) a bottom planar substrate enclosing flow channels which run beneath said microchambers; wherein said microchambers and said flow channels are connected by individual inlet ports through said micro-piercing injectors.

[0037] Manufacturing the microdevice elements into the substrate may be carried out using microfabrication techniques known in the art including photolithography etching, plasma etching or wet chemical etching. Alternatively, micromachining methods such as laser drilling, micromilling and the like may be employed.

[0038] The molecules or substances to be introduced into the plurality of cells may be introduced into the cytoplasm (transformation) or the nuclei (transfection). The molecules or substances to be introduced may be any molecules or substances of interest, but are typically selected from the group consisting of DNA, RNA, ribozymes, molecular probes, hormones, growth factors, enzymes, proteins, drugs, organic chemicals, inorganic chemicals, viruses and expression vectors. Organelles such as nuclei, mitochondria, chloroplasts and the like may also be introduced into the

cytoplasm of the target cells using the disclosed devices. Introduction of nuclei, for example, is particularly useful for technologies like cloning which employs nuclear transfer into a recipient oocyte.

[0039] The cells to be transformed by the present invention may be any cells of interest. In particular, the cells may be selected from the group consisting of somatic cells, oocytes, stem cells, mammalian cells, spleen cells, myeloma cells, and plant cells. Transfection of oocytes and stem cells may have particular use in the transfection of transgenes in the design of transgenic animals. Further, where the recipient cell is an oocyte, the material to be inserted may also be another cell, such as a sperm cell or a stem cell in the case of nuclear transfer into an enucleated oocyte. Methods of nuclear transplantation are well known in the art as evidenced by U.S. Patent No. 4,664,097 of the Wistar Institute, herein incorporated in its entirety, and such methods may be readily adapted for use on a micro-level in the devices of the present invention. The microdevices of the present invention are also useful for fusing spleen cells and myeloma cells, i.e., hybridoma technology, for the purpose of making monoclonal antibodies. For instance, U.S. Patent No. 4,822,470 of the Baylor College of Medicine discloses a method for the poration and fusion of cells using radiofrequency electrical pulses in hybridoma technology and is herein incorporated by reference. Such applications could readily be accomplished using the micropores created by the present transformation devices. For instance, spleen cells from an immunized mammal could be isolated and entrapped into individual microwells of the disclosed devices, thereby being perforated and fused with a myeloma cell essentially simultaneously. The fused hybridoma cells could then be collected and screened for the production of antibodies having specific binding characteristics.

[0040] The microdevices of the present invention may be designed having microchambers of varying size to accommodate specific cell types. Preferred individual microchambers range in size from approximately 5 microns and above. Likewise, individual inlet ports may be designed in order to accommodate a specific molecule, substance or cell to be introduced into the target recipient cell in order to better control the amount of material entering cells during transformation. More specifically, inlet ports may range in size from about 1 micron and above.

[0041] The microfabricated array module of the present invention may be made of any material commonly used in the micromachining art. For instance, such materials include silica, silicon, silicon carbide and gallium arsenide to name a few.

Preferably, the array substrate should be made of a microfabrication facilitating substance which may also be heated or cooled depending on the use of the device. The top and bottom planar substrates are most preferably glass, but may also be made of any suitable micromachining material such as silica, silicon, silicon carbide, gallium arsenide, glass, silicon elastomer (silicone), fused quartz, plastics and photo-etchable glass (Foturan™).

[0042] As described briefly above, the microdevice is designed with micro-fluidic flow channels beneath the microchambers that deliver biological and other molecules to the entrapped cells on the array. The device may be specially designed wherein independent, unconnected flow channels feed different groupings of microchambers for simultaneous targeting of different molecules or substances to different cells on the array. The microdevice may also include multiple layers of arrays, bottom and top substrates for high throughput, and also for delivering different molecules simultaneously through independent, unconnected flow channels.

[0043] The cross-sectional dimension of an individual flow channel will depend on the particular application of the microdevice. For instance, if cells are to be transformed simultaneously with the same molecule or substance, one flow channel may feed more than one well in the array. Alternatively, individual unconnected flow channels may be designed for the purpose of feeding individual inlet ports. Flow channels may also be fluidly connected to a fluid feeding and/or direction system for introducing and/or directing said molecules or substances into said microdevice.

[0044] As described above, the microdevices of the present invention entrap cells into microchambers using applied hydrostatic pressure. The devices may be further equipped with a pressure means for pressurizing or applying pressure to the top substrate, whereby the amount of pressure may be easily controlled by the operator. Suction from below the trapped cells could also be used to assist in entrapment of cells, either independently or in conjunction with hydrostatic pressure.

[0045] The microdevices of the present invention are preferably designed with an array substrate that conducts heat, so that that cells may be heated or cooled depending on the micro-operation to be transformed. For instance, where heating of the cells facilitates the transformation process, the array substrate may be further connected to a heater element, and said heater further connected to an adjustable power source. A temperature sensor and monitoring means would also be

incorporated so that the operator could readily adjust and monitor temperature levels. In some cases, it may be advantageous for the array substrate to be connected to a voltage supply which provides an adjustable electrical pulse, for instance, for nuclear transfer applications. Miniaturized devices such as heaters and voltage devices for carrying out a variety of synthetic and diagnostic operations are described in U.S. Patent No. 6,132,580 (The Regents of the University of California), which is herein incorporated by reference in its entirety.

[0046] The top planar substrate of the microdevices described herein may incorporate openings for washing away untrapped cells, and/or supplying or washing away medium or specific molecules or chemicals or radioactive labels to or from entrapped cells (see Fig. 1). The array substrate and/or top substrate may be optionally connected to a sample handling system that permits the transfer of cells from microchambers to outside analytical or collection devices.

[0047] A particularly useful sample handling system comprises individual exit ports for each microchamber, or groups of microchambers, wherein said exit ports are connected to individual flow channels.

[0048] Cells may be collected or routed into sample handling devices using any convenient means known in the art. For instance, the sample handling system may be further connected to a vacuum or pressure means for effectuating movement of said cells from said microchambers into said exit ports and/or said exit channels. Electrical currents and thermal expansion may also be used to effectuate sample movement. In this regard, U.S. Patent No. 5,872,010 (Northeastern University), herein incorporated by reference, describes "off-chip" microscale liquid handling systems whereby small quantities of a fluid sample from a spatially concentrated environment of a microscale device may be transferred through individual exit ports to a collection device without an increase in sample volume. Similar techniques may be applied to the chips of the present invention following cell transformation using exit port adaptors and flow channels. Cell-sorting using magnetically tagged cells and an external magnetic field could also be used.

[0049] Outside analytical or collection devices which may be used in conjunction with the microdevices described herein include secondary microfabricated arrays of microchambers or multiwell plates, e.g., for culturing cell populations from individual transformed cells; filters or films for conducting hybridization, e.g., Southern, Northern and Western analyses; apparatus for receptor/ligand analyses, e.g. screening

transformed cells for those which express a particular ligand or receptor and bind to another molecule or protein of interest; apparatus for immunological screening, e.g., of antibody producing hybridoma cells; devices for radioactivity measurements, e.g., of transformed cells labeled with a radioactive isotope; flow cytometry or FACS apparatus, e.g. to screen cells for the expression of surface proteins encoded by transfected genes or for other changes in gene expression; mass spectrometry or nuclear magnetic resonance analyses, chromatography, and fluorescence imaging.

[0050] The present invention also includes methods of using the disclosed microdevices for introducing molecules or substances simultaneously into a plurality of cells, and also the transformed, transfected or fused cells produced thereby. Methods of using the transformed cells for diagnostic applications and further analyses as proposed above are also included. For instance, the transformed cells of the present invention could be used to identify genes of interest, for high throughput hybridoma screening and efficient identification and isolation of monoclonal antibodies, for the production of useful proteins, for the screening of drugs and pharmaceuticals, and for the production of transgenic animals.

[0051] The present invention may be distinguished from silicon chip-based micro-injection techniques of the prior art by the single module nature of the microchamber/injection apparatus. Accordingly, the present invention includes a method for simultaneously positioning and perforating a plurality of cells, comprising (a) positioning cells on a single microfabricated array substrate that incorporates integrated micro-piercing structures within microchambers; and (b) entrapping cells in said microchambers using hydrostatic pressure applied from above such that said cells are perforated by said micro-piercing structures. Molecules, substances, organelles or other cells of interest may be introduced into or extracted from said plurality of cells during perforation. The microdevice may also be used to remove cellular contents for the purpose of isolating cell membranes, e.g., erythrocyte ghosts. Typically, the plurality of cells is exposed to said molecules, substances, organelles or other cells of interest by way of a flow channel encased by a bottom substrate underneath said array substrate.

[0052] Also included in the present invention are kits comprising the disclosed microdevices, which may optionally comprise accessory devices such as a heater and power source for altering the temperature of the array substrate. Although one advantage of the microdevices described herein is ease of manufacture and the

feasibility of mass production, microdevices may also be custom design according to a particular cell type, transformation application or desired analytical apparatus.

Heating units may also be built into the microdevice array substrate rather than sold as a separate unit. Kits of the present invention may further comprise a sample handling system comprising individual exit ports and flow channels for each microchamber or group of microchambers, which may be optionally connected to a vacuum or pressure means for effectuating movement of said cells from said microchambers into said exit ports and/or said exit channels for subsequent analysis or collection.

[0053] The present invention is further described by reference to the following examples, that are intended for purposes of illustration only and should not be construed to limit the scope of the claimed invention.

Example 1

[0054] The microdevice structure (Fig. 1) is based on a single chip module containing a large array of microchambers in a silicon substrate that houses recipient cells to be transformed (Fig. 1). Inlet ports located at the bottom of each microchamber are integrated into the device in such a way as to simultaneously render micro-piercing injectors during microchamber fabrication (Fig. 2). The silicon structure is bonded with a glass substrate on the top in order to introduce recipient cells into the microsystem, and to allow the application of hydrostatic pressure. A glass substrate is also bonded to the bottom of the device, which contains the micro-fluidic channels for biological and molecular component transport (Fig. 1).

[0055] Initially, the cells are allowed to settle onto the bottom of each microchamber, and when all microchambers are filled by the cells, hydrostatic pressure is applied from above to trap and hold them in place. During the entrapment process, the cell membranes are perforated mechanically by the micro-piercing structures. The inlet ports then act as micro-injectors through which biological material and/or molecules can be introduced into the cell using positive pressure. This pressure is applied shortly after the application of the trapping hydrostatic pressure from above in order to prevent the escape of cell cytoplasm through the perforation.

[0056] Aside from the various standard integrated circuit processing requirements, the fundamental fabrication steps involve silicon micromachining, from simple bulk micromachining to deep reactive ion etching (DRIE) procedures. Similarly, for the

top and bottom glass substrates, wet chemical etching will be necessary to create fluidic channels for cell and material transport.

[0057] First Embodiment: device based on etched microchambers

Isotropic Etching

[0058] The core aspect of this microdevice is the creation of the injector structure during the same time that the micro-chambers are being formed. The use of isotropic etchants is ideal for the formation of the desired profile in silicon. The ability to etch silicon crystal planes at the same rate in all directions is the defining characteristic of isotropic etchants. By using a masking layer that is not attacked by a given isotropic etchant, a pattern can be lithographically printed in the mask to expose certain areas of silicon to the ambient. The chemistry of the etching process produces an attack of the silicon material underneath the masking layer, due to the etchants' isotropic nature, thereby creating a hemispherical cavity within the silicon substrate. The undercutting of the masking layer, illustrated in Fig. 3, can be used to great advantage for the simultaneous creation of a micro-chamber and micro-injector structure.

[0059] The masking pattern should therefore be designed in order to form a circular cavity within the silicon substrate to hold the recipient cell, with a sharp protrusion at the bottom of each cavity to form the injector. This etch profile can be accomplished with an annulus or donut-shaped masking pattern where the area between the two concentric circles is bare silicon, and therefore, the region to be etched. The inner circle acts as a mask over which the isotropic etchant would remove the silicon, by means of undercutting, to create the protrusion while the outer circle will provide the radial dimension of the resulting cavity. The top and cross-sectional views of the masking pattern have been shown in Fig. 4.

[0060] Either wet or dry isotropic etching can be performed, where the former consists of wet chemistries, typically a mixture of hydrofluoric acid (HF), nitric acid (HNO₃), and acetic acid (CH₃COOH). This etchant, referred to as "HNA" has some limitations in its use because the resulting etch profile is highly agitation-dependant and sensitive to temperature (Madou 1997). In addition, it is difficult to mask with any precision since HNA can etch the masking layer very quickly. This makes it quite difficult to control lateral undercutting as well as vertical etch depth. Dry isotropic etching is further divided into plasma-assisted etching and gas-phase etching. Plasma-assisted etching involves creating an area of high energy electric and magnetic fields in a vacuum chamber that cause a gas to dissociate to form highly energetic ions,

photons, electrons, and reactive radicals and molecules, which establish the etching process. Thus, with this type of reactive ion etching (RIE), various etch profiles can be achieved by adjusting the chemistry and flow rates of the gases involved. Etch cavities can range from isotropic to profiles with near-vertical sidewalls. The RIE species to be used for the proposed microdevice will be sulfur hexafluoride (SF_6), which will etch silicon but that does not adversely affect an aluminum masking layer.

[0061] Gas-phase etching is always accomplished using xenon difluoride (XeF_2) to generate etching species without the need of a plasma (Madou 1997). Xenon difluoride is a white crystalline solid at room temperature and atmospheric pressure, having a vapor pressure of about 4 Torr at these conditions [Ann]. Exposed areas of silicon etch in the vapor, or dry, phase at room temperature and at pressures between 1 to 4 Torr, which can be established by a simple vacuum pump. XeF_2 exhibits a high selectivity to silicon over such common masking materials as silicon-oxide (SiO_2), silicon-nitride (Si_3N_4), aluminum, and photo-resist.

[0062] By controlling the isotropic etch duration of the masking pattern shown in Fig. 4, the resulting micro-cavities formed in the bulk silicon substrate have slight yet important differences. In Fig. 5, the progression of etch time duration is illustrated, with the shortest amount of time given by (a), and the longest given by (c). From Fig. 5, it is apparent that in order to form a micro-chamber with a protruding micro-injector at the bottom of each cavity, the profile of the two individual etches must come into contact. In Fig. 5a, the etch time is not long enough to permit contact, so that after the mask is removed, a flat silicon plateau will remain between the two etch cavities. In Fig. 5b, the etch cavities are touching, which would indeed create a protruding micro-injector. However, for a truly robust microdevice, the height of the micro-injector should ideally be contained entirely within the confines of the micro-chamber in order to avoid the possibility of damage during either device fabrication or operation. Therefore, by allowing the two etch cavities to merge, as shown in Fig. 5c, a recessed micro-injector is formed at the same time the micro-chamber is defined.

[0063] With the micro-injectors and micro-chambers in place, the inlet port must be incorporated into the micro-piercing injectors in order to allow the transfer of biological materials or molecules. The inlet port would simply need to be a small access tube starting at the back-side of the silicon wafer, terminating at the tip of the micro-injector. The technique used to fabricate such a hole relies on dry anisotropic etching using highly reactive ion species to chemically attack the silicon substrate.

[0064] Finally, wet isotropic etching will also be used to create the micro-fluidic channels in the top and bottom glass substrates. The substrates will then be aligned and bonded to the silicon wafer using high temperature and high voltage anodic bonding techniques. The glass will be either a standard pyrex-7740 wafer or the newer Foturan photo-etchable glass substrate. Both have thermal expansion coefficients similar to silicon and therefore introduce no stress when anodically bonded at high temperatures. Both 7740 and Foturan are etched in hydrofluoric (HF) acid.

Anisotropic Etching

[0065] Anisotropic etching of silicon is a fundamental technology required in the fabrication of both the inlet ports, and of the back-side reservoirs where the biological material or molecules will be stored prior to insertion into the recipient cells. The quaternary alkaline silicon etchant known as tetra-methyl ammonium hydroxide (TMAH) will be used to create the back-side reservoirs. Typically, wet anisotropic solutions have crystallographic-dependant etch rates, and for TMAH, the $\langle 111 \rangle$ planes of the silicon crystal lattice etch the slowest with respect to $\langle 100 \rangle$ and $\langle 110 \rangle$ planes. For a (100) oriented wafer, etch profiles are usually in the form of inverted pyramidal cavities aligned with the wafers' $\langle 110 \rangle$ primary flat. The slopes of the pyramidal pit correspond to the $\langle 111 \rangle$ planes, which intersect the $\langle 100 \rangle$ plane at 54.7° . This is the reason why the back-side of the microdevice in Figs. 1 and 2 have sloping sidewalls, which correspond to the $\langle 111 \rangle$ planes.

[0066] In contrast, reactive ion etching, or RIE, is a dry anisotropic process that is not dependent on crystal planes. Rather, the etch profile produced by RIE ranges from a relatively isotropic-like nature to a profile with near-vertical sidewalls, as mentioned earlier. With a new technology known as deep reactive ion etching (DRIE), holes can be made in a silicon wafer which extend from the front-side to the back-side with nearly vertical sidewalls. This technology will be used for creating the inlet ports in the micro-injectors. Based on Fig. 5, if the masking layers were removed from each of the cross-sectional views, then with the inlet port in place, the devices would appear as shown in Fig. 6.

Fabrication Process Flow

[0067] Fabrication of the microsystem will follow two parallel processes, with one involving an ultra-thin 4' silicon wafer while the other employing a 4" SOI, or silicon-

on-insulator wafer. Testing of specific process flow steps will be performed on standard 4" silicon wafers. The reason for using either ultra-thin or SOI wafers is because the overall diameter of the cavity is being designed for 10 μm , to accommodate cells of comparable sizes. Therefore, the isotropic etch that creates such a cavity will etch downwards by only 5 μm , since the diameter is formed by undercutting the masking layer on all sides of the circular annulus. Deeper cavities to accommodate the cells should be made by performing a relatively anisotropic RIE process. The thickness of the ultra-thin wafer will be approximately 20 μm whereas the SOI wafer will be that of standard thickness, typically 500 μm . It is clear that by a fabrication standpoint, the SOI wafer will be easier to handle and process as compared with the ultra-thin wafer, which can prove to be difficult to handle due to their fragility. The fabrication process for both types of wafer has been given in Fig. 7. Both processes are somewhat equivalent, beginning with a silicon surface oxidation followed by a DRIE step to create the inlet port. However, for the ultra-thin wafer, the lithography defining the pattern for the inlet port using DRIE is done on the back-side of the wafer, while for the SOI, it is done on the front. Once the DRIE has been done, the original silicon-dioxide layer is removed and a new layer of SiO_2 is grown on all exposed silicon surfaces, including within the inlet port hole. Both wafers undergo the second lithographic step on the front-side that is used to define the annuli, each being centered and aligned with the inlet port hole. Once defined, an anisotropic RIE step can be applied in order to increase the depth of the resulting micro-cavity, followed by an isotropic etch. This dry etch procedure can be made in two ways, and investigations will be made with either xenon-difluoride gas-phase etching or with sulfur hexafluoride plasma etching. The result of this step is the creation of a micro-cavity similar to that shown in Fig. 6c. For the SOI wafer, an additional step is required before the SiO_2 can be removed from both of the wafers. Since the SOI wafer is thick and the inlet port still inaccessible (refer to Fig. 7), an additional back-side anisotropic bulk silicon etch is needed using TMAH solution. The final micro-cavity with integrated piercing structures results in both cases.

Results

[0068] A series of trials were run to determine the optimal etching strategy for producing the microdevice. KIC software (developed at the University of California at Berkeley) was used to design a mask for etching an array of annuli of varying dimensions. The masks were printed on a linotronic output transparency at a local desktop publishing company resulting in annuli with a resolution of about 20 microns, sufficient for initial testing of etching procedures. The annuli had inner radii ranging from 10 to 30 microns in increments of 10 microns, and outer radii ranging from 20 to 60 microns in increments of 10 microns.

[0069] XeF_2 etching was attempted at first but proved unsuccessful, possibly due to the formation of a polymer-like film on the silicon surface during the etch procedure. Baking the silicon at 140°C for a short time (~10 minutes) may remove the unwanted surface adherents prior to etching which should produce more favorable results. This experiment will be re-attempted in the future.

[0070] Sulfur hexafluoride etching proved more successful. Initially, tests were conducted using an oxide masking layer to determine the relative isotropy of the RIE recipe. Simple test structures were etched to determine etch profile, as shown in the scanning electron micrograph (SEM) micrograph of Fig. 8. Aluminum was deposited on a silicon wafer, followed by photoresist, placement of the mask, UV illumination, aluminum etch, and finally SF_6 etch. An SEM of a portion of the resultant array of annuli is shown in Fig. 9. SEMs of two micro-cavities in the array are shown in Figs. 10 and 11. Their surface topography scans are also given in Figs. 12a and b, respectively. The depth of the two micro-cavities are equal because both were parts of the same array that were etched for equal times. But since their dimensions (inner and outer diameters), are different due to the different annuli masking dimensions, the inner projection that forms the micro-injector has a different height. None of the smallest diameter annuli (10 micron inner diameter) patterned successfully, due to the limited resolution of the mask. It should be evident that the annuli profiles are not clean surfaces and exhibit tremendous roughness. This is due to the aluminum masking layer that was used since the RIE procedure affects the aluminum causing it to precipitate onto the etching silicon surface. As a result, the aluminum on the etch front produces a micro-masking effect leading to excessive surface roughness. This problem can be alleviated by the use of an oxide masking layer. Indeed, as seen in Fig. 8, the etch profile is clean and there is no surface roughness on the silicon that is

etched. The aluminum masking layer was used since it is a quick procedure to deposit, and could also be used for masking in a XeF_2 environment.

[0071] A second series of experiments were conducted to characterize important etch processes, using mask geometries larger than those of the final microstructure, to determine a microfabrication strategy that would produce the micro-injector structure illustrated in Fig. 1. The results obtained in conjunction with these experiments are shown in Figures 13-16. Reactive Ion Etching (RIE) tests for silicon isotropic/anisotropic etching were performed to determine the optimal recipe for our final device. A mixture of O_2 and SF_6 gases were introduced into the RIE in various proportions and a plasma was struck at different power levels. Investigations were made of both silicon (Si) and silicon dioxide (SiO_2) etch rates, the etch selectivity between Si and SiO_2 , and the degree of anisotropy of the etch. The test structure, shown in Fig. 2, consisted of a series of annuli patterned in silicon, masked by a thermal oxide layer. The annuli had inner radii ranging from 30 to 60 microns in increments of 10 microns, and outer radii ranging from 50 to 100 microns in increments of 10 microns, with a resolution of about 20 microns, sufficient for initial testing of etching procedures. All etches were performed for 5 minutes at 85 mTorr, and etch depths were measured using a Dektak profilometer. The mask underetch data was visually determined using an optical microscope while calculations were performed to arrive at the selectivity, etch rate, and anisotropy. Graphical results for only three trials are discussed below.

[0072] These experiments helped determine the RIE recipe to form the final micro-needle structure, taking into account the desired shape, etch depth, and mask underetch rate. It was concluded that the anisotropy of the final etch be between 1 and 2, while a selectivity of greater than 100 is also preferred. The lower power RIE using 95W RF power is more desirable because the resulting etched surface is smoother than with other power levels. It was also determined that a 10% O_2 and 90% SF_6 gas mixture yielded a suitable etch profile, and that a pressure between 80 to 90 mtorr gave the best results since it provided high selectivity. Pressure does not greatly affect the anisotropy, however experiments revealed that higher pressures correlated to both higher selectivities and Si etch rates. For the CTM micro-needle fabrication, the recipe to be used will have a 10% O_2 -90% SF_6 gas mix at 85mtorr and 95W RF power.

[0073] The inlet port in the micro-injector structure (Fig. 1) can be fabricated through a commercial MEMS service provider possessing Deep-RIE (DRIE) technology ideal for etching a 1-2 μm diameter holes in the silicon substrate to a depth of about 30 μm .

[0074] In addition to characterizing the RIE, the method by which hydrostatic pressure is applied was further analyzed with the aid of a macro-model of the CTM, shown in Fig. 17. In the original design, manual syringes located at ports A, B, C, and D (Figs 17) are used in the microsystem to control the hydrostatic pressure (A), to transport the recipient cells before and after injection (B and C), and to allow the transfer of material into the host cells (D). This concept assumed an empty (air-filled) micro-needle that acts as a stiff damping element. The application of large hydrostatic pressures in this design will not necessarily impel the recipient cells to be seated in their respective micro-chambers, and could potentially break the silicon membrane. Furthermore, the added pressure would displace the air in the micro-needle downward due to the piston-like action of the free moving syringe (D). At the time of injection, it is likely that this displaced air would be introduced into the cell, and since fluid inside the cell is incompressible, the cell may be forced off the micro-needle with little or no material being inserted. Alternatively, the material to be injected could be pre-loaded in the micro-needles (fluid-filled) prior to injection, however, due to the lack of venting below the cells to be trapped, the design does not allow for the downward displacement of cells by the action of increased hydrostatic pressure. The result is that the cells are not seated in the micro-chambers due to the incompressibility of fluid below the cell. The shortcoming of the design is that the micro-injector is used during both cell trapping and material injection phases. To improve the probability of cell seating and material injection, the initial design was modified to allow for venting of the fluid trapped below the cells as they are pushed down onto the micro-needles. Ports were considered for the design (Fig. 18) to provide a means for fluid escape during the cell trapping operation, allowing the micro-injectors to be pre-loaded with the material to be introduced. However, since the 30-40 μm deep vent and inlet ports would be made using DRIE, an *optimistic* minimum diameter for each hole, taking into account some unavoidable lateral etch, would be about 1.5 μm . Considering the micro-chamber is a 10 μm diameter cup, designed to be slightly less than the size of a host cell, performing lithography and processing in such a confined space would be

difficult. A new design incorporating fluidic channels for venting and suction was developed, and is described in the next section.

[0075] Second Embodiment: device based on microchambers obtained by molding PDMS substrate.

[0076] In a second embodiment of the invention a design was conceived that eliminated the etched micro-chambers so the micro-needle array could be formed on the silicon surface. An intermediate structural layer made of polydimethylsiloxane (PDMS) silicone rubber, which uses standard silicon micro-technologies and a molding method for processing, was added between the silicon and top glass substrate. This new layer contains an array of micro-tubes 10 μ m in diameter that are aligned above the micro-needle array on the silicon. The micro-tubes are the seating locations for the host cells, which are drawn into these holes using a combination of applied hydrostatic pressure applied and suction through the fluidic channels formed in the PDMS layer, as depicted in Fig. 19. This design alleviates the need of isotropically etched micro-chamber fabrication, thereby eliminating the need for costly ultra-thin or silicon-on-insulator (SOI) wafers, which were in the original proposal. Since the microsystem is fabricated with standard silicon wafers, backside anisotropic etching is used to access the micro-needle injector ports. PDMS will also be used to *backfill* this large etch cavity to reduce its volume thereby reducing the amount (cost) of material to be injected. Fabrication of the top silicone layer relied on casting uncured PDMS onto a double-spun epoxy-based thick SU-8 photoresist mold that was patterned with the fluidic channels and micro-chamber. After the PDMS had cured, it forms a durable device that can be peeled from the mold. Experiments were conducted to find the best recipe for a double-spun SU-8 layer and to find a sacrificial release layer between the PDMS and SU-8 for ease of microstructure removal. Results obtained in connection with this embodiment of the invention are shown in Fig. 20.

Testing the Microsystem

[0077] Initial testing of the microdevice will determine if cells can be successfully pierced by the microinjectors and fluid injected. Fluorescent dye will be put in the lower reservoir of the microdevice and mammalian cells in the upper reservoir. The cells will be allowed to settle into the cavities, pressure in the upper reservoir will be increased until the cells are punctured, a pressure pulse applied to fluid in lower chamber to eject dye laden fluid into the cells. Cells not trapped in the cavities will be

removed by a small flow of fluid horizontally in the upper chamber. The whole process will be observed in real time via a microscope with fluorescent capability. The cells will finally be removed from the microdevice and examined for successful injection of fluid by the presence of fluorescence.

[0078] For testing the microdevice to successfully transfect cells, we proceed as follows (Maniatis1989): A commercial vector designed for transfection of mammalian cells and which contains a gene for expression of green fluorescent protein will be loaded into the microdevice and injected into cells as described above. The injected cells will be assayed for viability by growth as clones on agar. Within a few hours of injection, single cells will be assayed for successful transfection and expression by assay under fluorescence microscopy following inoculation onto a polylysine coated coverslip. For expression of larger soluble proteins, cells will be injected with an expression vector for beta-galactosidase and clones assayed by a commercial color development assay. For nervous system genes, commercial vectors will be cut with appropriate restriction enzymes followed by insertion of cDNA that specifies a protein of interest, such as carboxypeptidase II or the metabotropic glutamate receptor subtype 1. Clones will be assayed by standard methods used in Professor Neale's laboratory, substrate hydrolysis for the enzyme and receptor mediated increase in intracellular calcium for the receptor.

3.6 Significance of the Project and its Clinical Potential

[0079] Techniques for the incorporation of exogenous molecules into cells has advanced the determination of pathways of a variety of protein synthesis, enzymatic and immune system processes, in vitro testing of drugs, and gene therapy. Such techniques have therefore become critical tools in cellular and genetic research, as well as in therapeutic applications. Improved methods for delivering molecules to cells is therefore critical for the advancement of basic research, biotechnology and for clinical applications. One such clinical application, gene therapy holds the promise of revolutionizing the treatment of disease. There are over 4000 genetic diseases, and virtually every disease is influenced by a genetic component. Gene therapy consists of the introduction of DNA that encodes a specific protein into cells to produce a therapeutic effect, such as the production of an enzyme that the cell is unable to produce due to a defective gene. In *ex vivo* transfection, defective cells are removed from the body, transfected, and returned to the body. The first human gene therapy

trial was for the treatment of an immunodeficient disease resulting from the inability of the body to produce the enzyme adenosine deaminase (ADA). Lymphocytes were isolated from a patient, exposed to a retrovirus carrying the ADA gene, and then returned to the patient. A more recent application uses transfection as insulin replacement therapy. Non-B-cell somatic cells removed from a diabetic patient were genetically altered *ex vivo* to produce and secrete insulin (Bailey et al 1999). Reimplantation of these transfected cells into the patient will theoretically obviate the need for insulin injections. Another promising area is in tumor immunization. Here, cells from the patient's tumor are removed, transfected with retroviral vectors containing either IL-2 or tumor necrosis factor (Rosenberg SA 1992, 1993). The cells are then injected back into the patient where they may increase the immune response to the bulk tumor. Our project will develop a silicon based microdevice to improve *ex vivo* transfection. Most current transfection methods suffer from one or more liabilities, resulting in low transfection rates. Our proposed device presents an improved methodology for transfection (and more generally for the introduction of any type of molecule into cells) over the current state-of-the-art. In particular, the device will: require minimally skilled expertise, handling and expenditure of time transform large numbers of cells in a single step maintain cell viability in a high percentage of cells be cost-effective overcome limitations inherent in other transfection microfabricated devices such as complex fabrication processing and device fragility, by using a simplified device fabrication strategy developing a single component device inherently more durable and robust than the current two component devices.

References:

- Bailey CJ, Davies EL, Docherty K (1999). Prospects for insulin delivery by ex-vivo somatic cell gene therapy. *J. Mol. Med.* 77, 244-249.
- Chun K, Hashiguchi G, Toshiyoshi H and Fujita H (1999). An array of hollow microcapillaries for the controlled injection of genetic materials into animal/plant cells. Twelfth IEEE International Conference on Micro Electro Mechanical Systems, 406-411, (Jan. 17-21) Orlando, Florida.
- Gainer AL, Korbitt GS, Rajotte RV, Warnock GL, Elliott JF (1996). Successful biolistic transformation of mouse pancreatic islets while preserving cellular function. *Transplantation* 61, 1567-1571.
- Klein Tm, Arentzen R, Lewis PA and Fitzpatrick-McElligott S (1992). Transformation of microbes, plants and animals by particle bombardment. *Biotechnology* 10 286-291 (1992).
- Klein TM, Wolf ED, Wu R, and Sanford JC (1987). High velocity microprojectiles for delivering nucleic acids into living cells. *Nature* 327, 70-73.
- Le Pioufle Surbled P, Nagai H, Chun KS, Murakami Y (1999). Tamiya E, and Fujita H, Attachment of Cells on Microsystems: Application to the Gene Transfection. *Transducers '99*, 768-771. The 10'th Annual Conference on Solid State Sensors and Actuators, (June 7-10) Sendai, Japan.
- Levine F and Friedmann T (1993). *Gene Therapy*. *Am J Dis Child* 147, 1167-1174.
- Madou Marc (1997). *Fundamentals of Microfabrication*. CRC Press, Boca Rotan.
- Maniatis T, Fritsch EF, and Sambrook J (1989). *Molecular cloning: a laboratory manual*, 2nd ed. Cold Spring Harbor, N.Y. Cold Spring Harbor Laboratory.
- McAllister DV et al (1999). Three-dimensional hollow micro-needle and micro-tube arrays. *Transducers* 1098-1101 (June 7-10) Sendai, Japan.
- Madry H, Trippel SB (2000). Efficient lipid-mediated gene transfer to articular chondrocytes. *Gene Therapy*, 286-291.
- Miller AD (1992). Retroviral vectors. *Curr. Top. Microbiol. Immunol.* 158, 1-24.
- Morgan RA and Anderson WF (1993). *Human Gene Therapy*. *Annu Rev Biochem* 62, 191-217.
- Mullen CA, Snitzer K, Culver KW, Morgan RA, Anderson WF, Blaese RM (1996). Molecular analysis of T lymphocyte-directed gene therapy for adenosine deaminase

deficiency: long-term expression in vivo of genes introduced with a retroviral vector. *Gene Therapy* 7, 1123-29.

Neumann E, Sowers AE, and Jordan CA (1989). *Electroporation and Electrofusion in Cell Biology*. Plenum Press, New York.

Pelicer A, Robins D, wold B, Sweet R and Jackson J (1980). Altering genotype and phenotype by DNA mediated gene transfection. *Science* 209, 1414-1422.

Rosenberg SA, Anderson WF, Blaese M, Hwu P, Yannelli JR, Yang JC, Topalian SL, Schwartzenuber DJ, Weber JS and Ettinghausen SE (1993). The development of gene therapy for the treatment of cancer. *Ann Surg* 218, 455-463.

Rosenberg SA (1992). *Human Gene Therapy* 3, 57-73.

Thompson DC, Frazier-Jessen MR, Rawat R, Nordan RP, and Brown RT (1999). Evaluation of methods for transient transfection of a murine macrophage cell line, RAW 264.7, *Biotechniques* 27, 824-826.

What is claimed:

1. A microdevice for introducing molecules or substances into a plurality of cells, comprising:
 - (a) an array substrate having a plurality of individual microchambers, wherein each microchamber is suitable for holding at least one cell and incorporates an integrated micro-injector;
 - (b) a top planar substrate for introducing and entrapping individual cells in microchambers positioned above the array; and
 - (c) a bottom planar substrate enclosing one or more flow channels which run beneath said microchambers positioned below the array at an opposite side of the top planar substrate;wherein said microchambers and said flow channels are connected by individual inlet ports through said micro-injectors.
2. The microdevice of claim 1, wherein said molecules or substances are introduced into the cytoplasm of said cells.
3. The microdevice of claim 1, wherein said molecules or substances are introduced into the nuclei of said cells.
4. The microdevice of claim 1, wherein said molecules or substances are selected from the group consisting of DNA, RNA, ribozymes, molecular probes, hormones, growth factors, enzymes, proteins, drugs, organic chemicals, inorganic chemicals, viruses and expression vectors.
5. The microdevice of claim 2, wherein said substances are organelles.
6. The microdevice of claim 5, wherein said organelles are nuclei or mitochondria.
7. The microdevice of claim 1, wherein said cells are selected from the group consisting of somatic cells, oocytes, stem cells, mammalian cells, spleen cells, myeloma cells and plant cells.

8. The microdevice of claim 7, wherein said substances are other cells.
9. The microdevice of claim 8, wherein said cells are oocytes, and said other cells are selected from the group consisting of sperm cells and somatic cells.
10. The microdevice of claim 8, wherein said cells are spleen cells, and said other cells are myeloma cells.
11. The microdevice of claim 1, wherein said plurality of individual microchambers are formed in a polydimethylsiloxane (PDMS) silicone layer.
12. The microdevice of claim 11, wherein the microchambers are in the form of microtubes formed in the layer.
13. The microdevice of claim 12, wherein the microtubes are formed by molding the PDMS layer.
14. The microdevice of claim 12, wherein the microtubes have a diameter of about 10 micrometers.
15. The microdevice of claim 12, wherein one or more holes are formed in the PDMS layer, wherein said holes are in communication with the microtubes to form fluidic channels thereby allowing the positioning of the cells in the microtubes through succession.
16. The microdevice of claim 15 further comprising PDMS backfill member positioned below the bottom substrate at a face of the bottom substrate opposite the array of microtubes.
17. The microdevice of claim 1, wherein said cells are entrapped in said microchambers by applied pressure from said top planar substrate and/or by suction through bottom substrate.

18. The microdevice of claim 1, wherein said single microfabricated array substrate is made of a material selected from the group consisting of silica, silicon, silicon carbide, gallium arsenide, glass, silucon elastomer (silicone), fused quartz, plastics and photo-etchable glass.

19. The microdevice of claim 1, wherein said top planar substrate is made of material selected from the group consisting of silica, silicon, silicon carbide, gallium arsenide, glass, silucon elastomer (silicone), fused quartz, plastics and photo-etchable glass.

20. The microdevice of claim 1, wherein said bottom planar substrate is made of material selected from the group consisting of silica, silicon, silicon carbide, gallium arsenide, glass, silucon elastomer (silicone), fused quartz, plastics and photo-etchable glass.

21. The microdevice of claim 1, wherein independent, unconnected flow channels feed different groupings of microchambers for targeting different molecules or substances to said cells.

22. The microdevice of claim 1, wherein said microdevice includes multiple layers of said array, bottom and top substrates.

23. The microdevice of claim 22, wherein said multiple layers incorporate independent unconnected flow channels.

24. The microdevice of claim 1, wherein the cross-sectional dimension of an individual flow channel is about 1 micron or above.

25. The microdevice of claim 1, wherein said flow channels are fluidically connected to a fluid feeding and/or direction system for introducing and/or directing said molecules or substances into said microdevice.

26. The microdevice of claim 1, further comprising pressure means for pressurizing said top substrate to entrap said cells into said microchambers.

27. The microdevice of claim 1, wherein said array substrate and/or top substrate may be optionally connected to sample handling system that permits the transfer of cells from microchambers to outside analytical or collection devices.

28. The microdevice of claim 27, wherein said sample handling system comprises individual exit ports for each microchamber, or which serve a group of microchambers, and wherein said exit ports are connected to individual flow channels.

29. The microdevice of claim 28, wherein said sample handling system is further connected to a vacuum or pressure means for effectuating movement of said cells from said microchambers into said exit ports and/or said exit channels.

30. The microdevice of claim 27, wherein said outside analytical or collection devices include secondary microfabricated arrays of microchambers or multiwell plates, filters or films for conducting hybridization, receptor/ligand analyses, immunological screening or radioactivity measurements, flow cytometry or FACS apparatus, mass spectrometry or nuclear magnetic resonance analyses, chromatography and fluorescence imaging.

31. A method of introducing molecules or substances into a plurality of cells using the microdevice of claim 1.

32. The cells produced by the method of claim 31.

33. A method of introducing molecules or substances into a plurality of cells using the microdevice of claim 2.

34. The transformed cells produced by claim 33.

35. A method of introducing molecules or substances into a plurality of cells using the microdevice of claim 3.

36. The transfected cells of claim 35.

37. A method of fusing cells using the microdevice of claim 9.
38. The nuclear transfer units produced by the method of claim 37.
39. A method of fusing cells using the microdevice of claim 10.
40. The hybridoma cells produced by the method of claim 39.
41. A method for simultaneously positioning and perforating a plurality of cells, comprising:
- (a) positioning cells on a single microfabricated array substrate that incorporates integrated micro-piercing structures within microchambers; and
 - (b) entrapping cells in said microchambers using hydrostatic pressure applied from above and/or suction from below such that said cells are perforated by said micro-piercing structures.
42. The method of claim 41, wherein molecules, substances, organelles or other cells of interest are introduced into said plurality of cells during perforation.
43. The method of claim 42, where said molecules, substances, organelles or other cells are introduced into the cytoplasm of said cells during perforation.
44. The method of claim 42, wherein said plurality of cells is exposed to said molecules, substances, organelles or other cells of interest by way of a flow channel encased by a bottom substrate underneath said array substrate.
45. The method of claim 41, wherein a cellular component or cell contents are extracted from cells during perforation.
46. The transformed, transfected or fused cells produced by the method of claim 42.

47. The cell membranes, components or contents isolated using the method of claim 45.

48. A kit comprising the microdevice of claim 1.

49. The kit of claim 48 further comprising a heater and power source for altering the temperature of the array substrate.

50. The kit of claim 48 further comprising a sample handling system comprising individual exit ports and flow channels for each microchamber or group of microchambers, which may be optionally connected to a vacuum or pressure means for effectuating movement of said cells from said microchambers into said exit ports and/or said exit channels for subsequent analysis or collection.

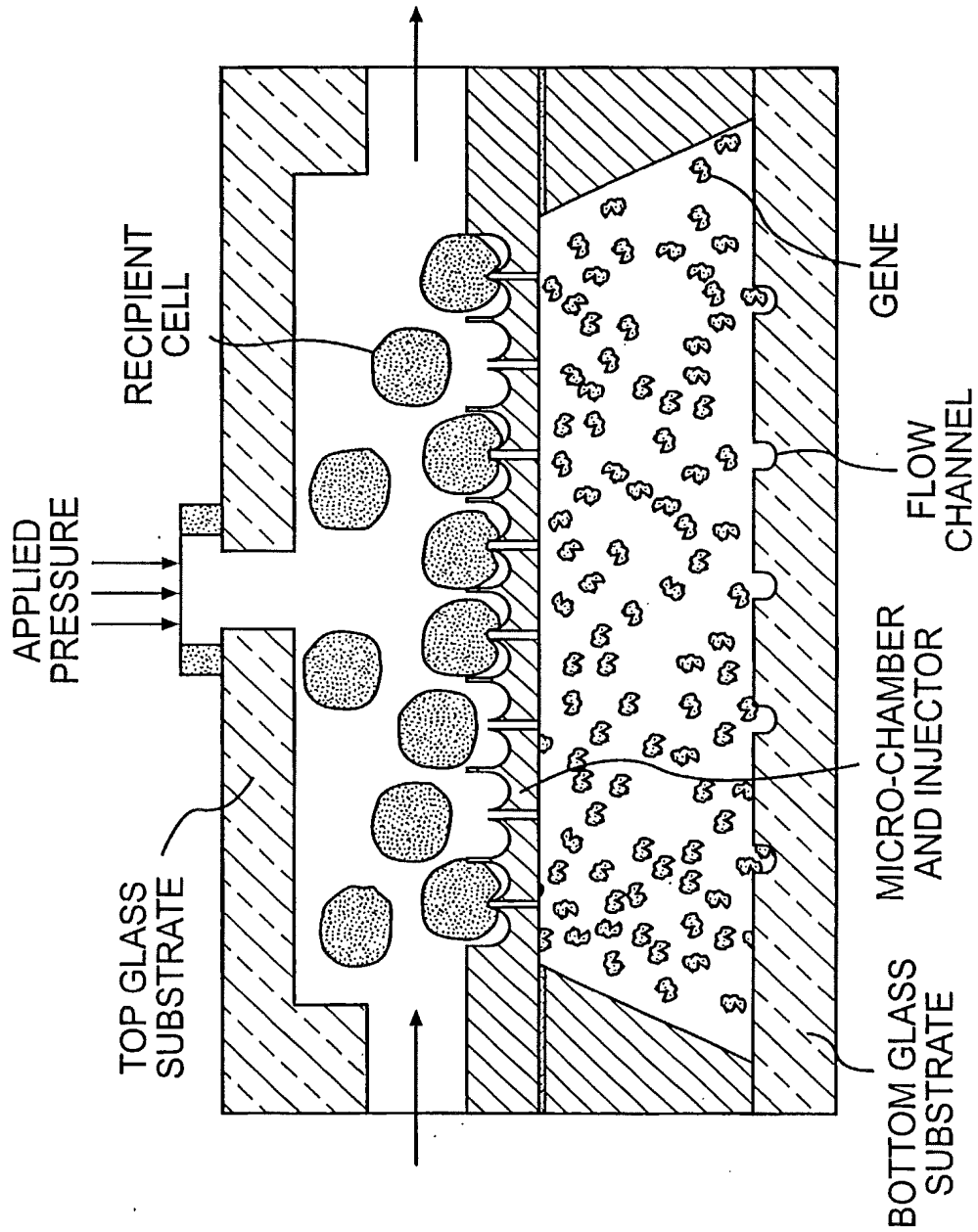
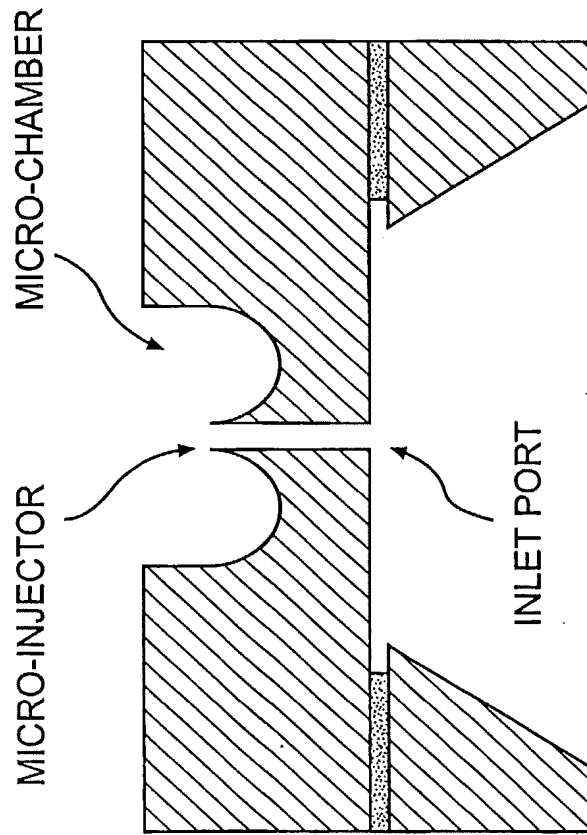

FIG. 1

CELL TRANSFORMATION MICRODEVICE



A REPRESENTATIVE VIEW OF
A SINGLE INJECTOR

FIG. 2

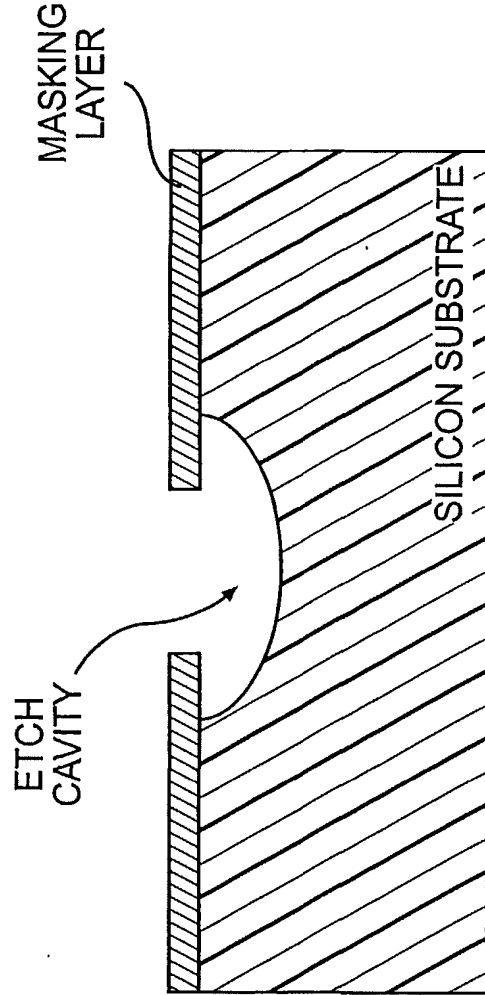

CROSS-SECTIONAL VIEW OF CAVITY FORMATION
USING A MASKING LAYER WITH AN ISOTROPIC ETCHANT

FIG. 3

4/15

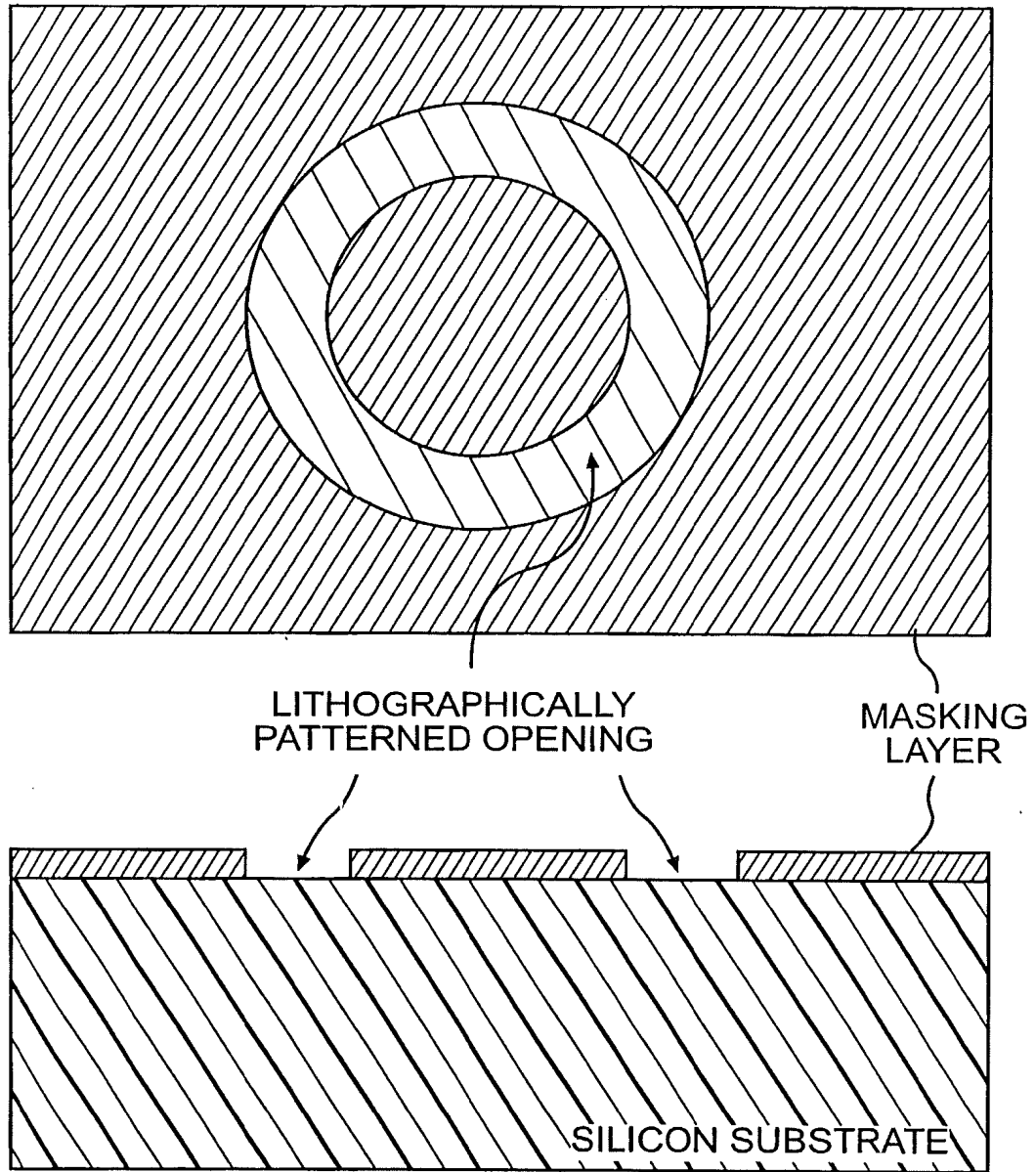

TOP AND CROSS-SECTIONAL VIEW OF THE ANNULUS MASKING PATTERN.

FIG. 4

SUBSTITUTE SHEET (RULE 26)

5/15

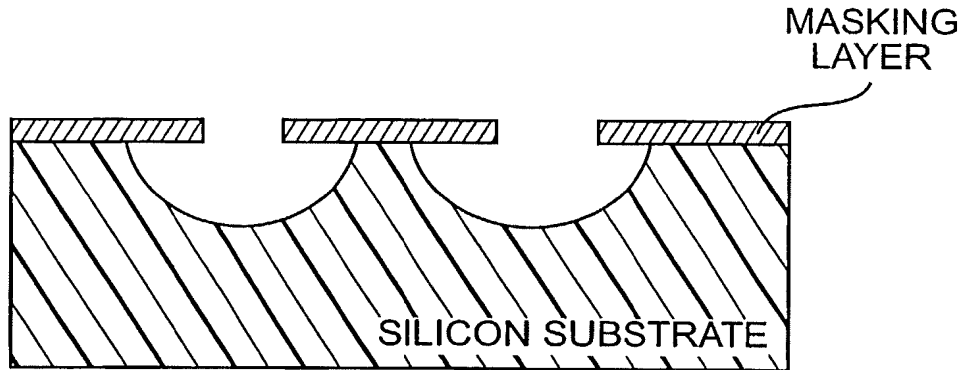

CROSS-SECTIONAL VIEW OF THE ETCH PROFILE OF ISOTROPIC ETCHING FOR VARYING TIMES.

FIG. 5a

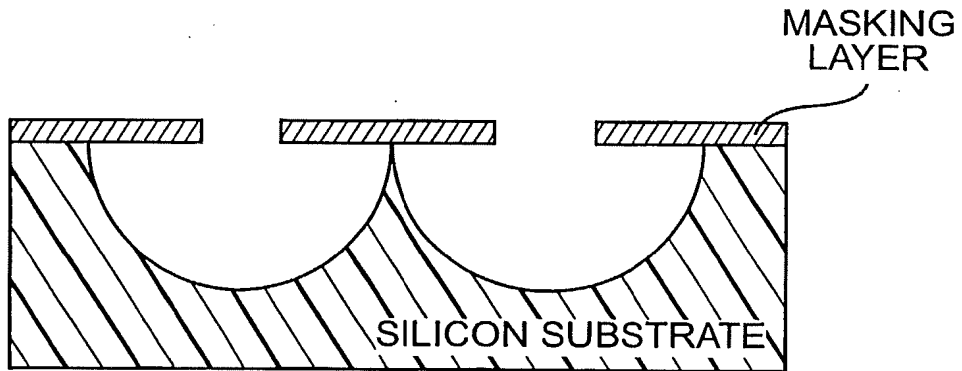

CROSS-SECTIONAL VIEW OF THE ETCH PROFILE OF ISOTROPIC ETCHING FOR VARYING TIMES.

FIG. 5b

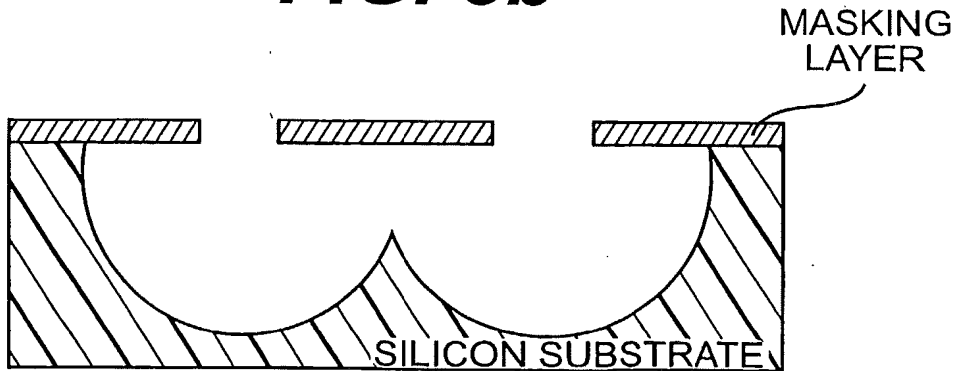

CROSS-SECTIONAL VIEW OF THE ETCH PROFILE OF ISOTROPIC ETCHING FOR VARYING TIMES.

FIG. 5c

6/15

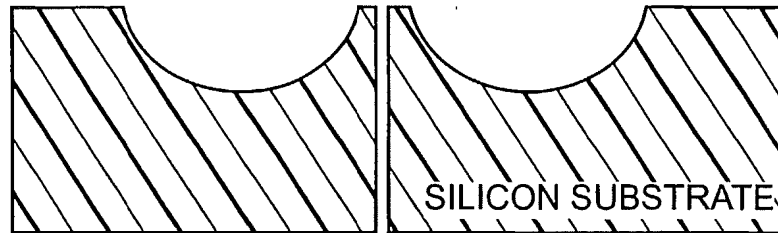

CROSS-SECTIONAL VIEW OF THE MICRO-INJECTOR WITH INLET PORT

FIG. 6a

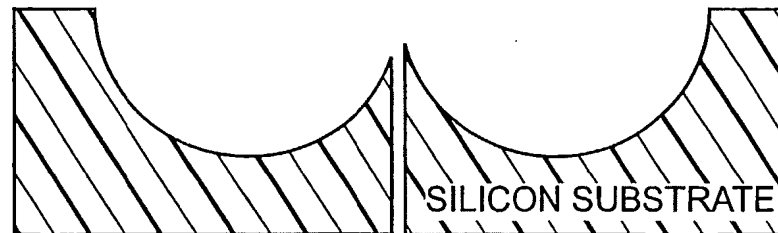

CROSS-SECTIONAL VIEW OF THE MICRO-INJECTOR WITH INLET PORT

FIG. 6b

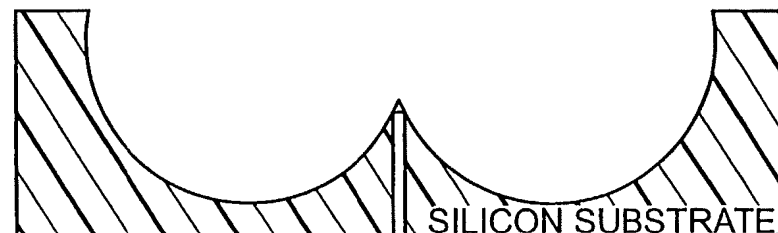

CROSS-SECTIONAL VIEW OF THE MICRO-INJECTOR WITH INLET PORT

FIG. 6c

7/15

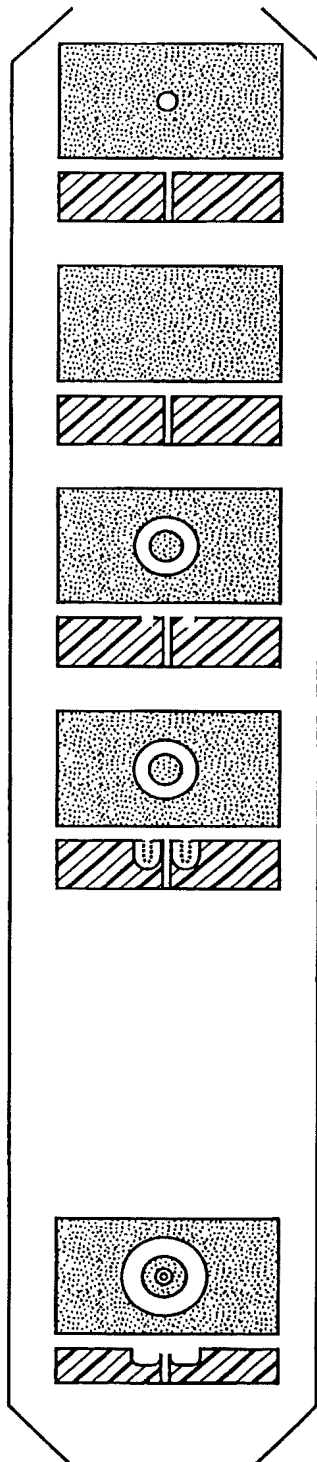

- SILICON SURFACE OXIDATION
- FRONT/BACK-SIDE LITHOGRAPHY
- DEEP DRY ETCHING (DRIE)

- DEPOSITION OF SILICON OXIDE

- WAFER FRONT-SIDE LITHOGRAPHY
- ANISOTROPIC SILICON DRY ETCHING (RIE)

- SILICON ISOTROPIC DRY ETCHING (RIE)

- BACKSIDE WAFER LITHOGRAPHY
- SILICON ANISOTROPIC ETCHING (TMAH)

- SILICON OXIDE WET ETCHING

FIG. 7a

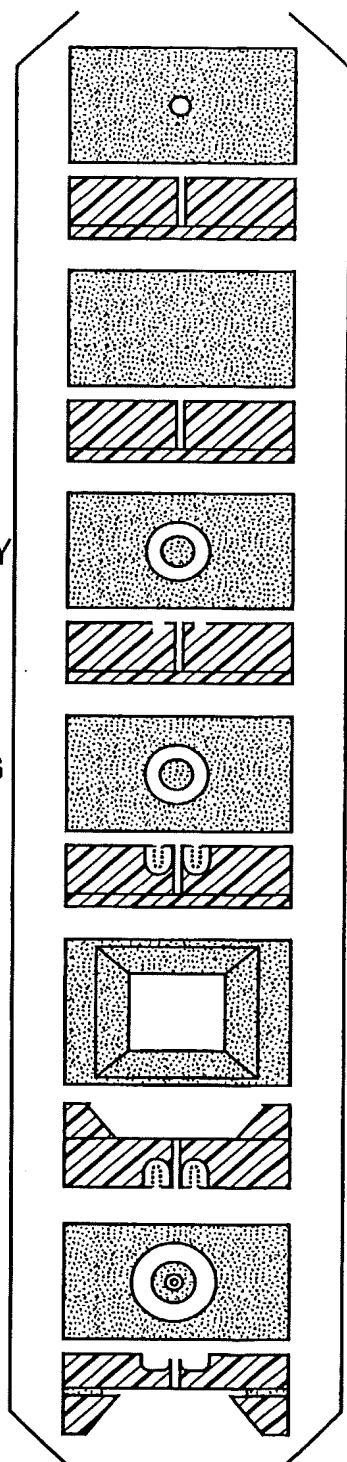
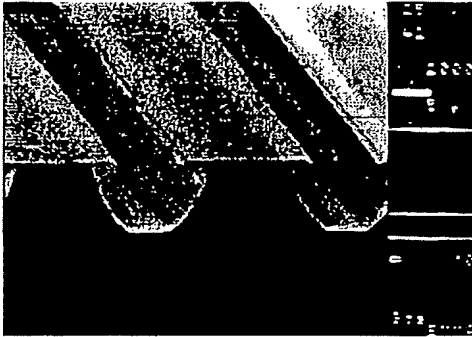

FIG. 7b

FABRICATION PROCESS FLOW FOR (a) ULTRA-THIN WAFER, AND (b) SOI WAFER. THE ONLY DIFFERENCE IN THE FABRICATION SEQUENCE SHOWN ABOVE IS IN THE FIRST STEP WHERE FRONT-SIDE LITHOGRAPHY IS DONE ON THE SOI WAFER, WHILE BACK-SIDE LITHOGRAPHY ON THE ULTRA-THIN WAFER.



AN SEM OF THE TEST
STRUCTURE FOR DETERMINING
RIE ISOTROPY

FIG. 8

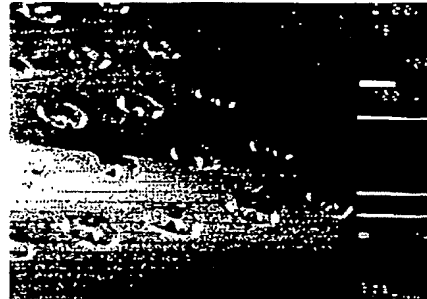

AN SEM OF THE ANNULI
TEST STRUCTURE

FIG. 9

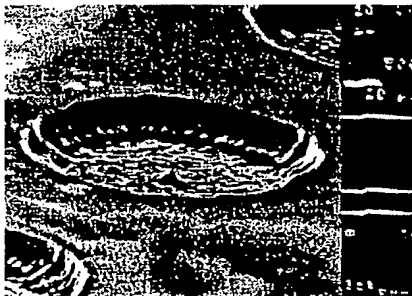

SEM OF ONE ANNULUS
TEST STRUCTURE

FIG. 10



SEM OF AN ANNULUS
TEST STRUCTURE
OF DIFFERENT DIMENSION

FIG. 11

9/15

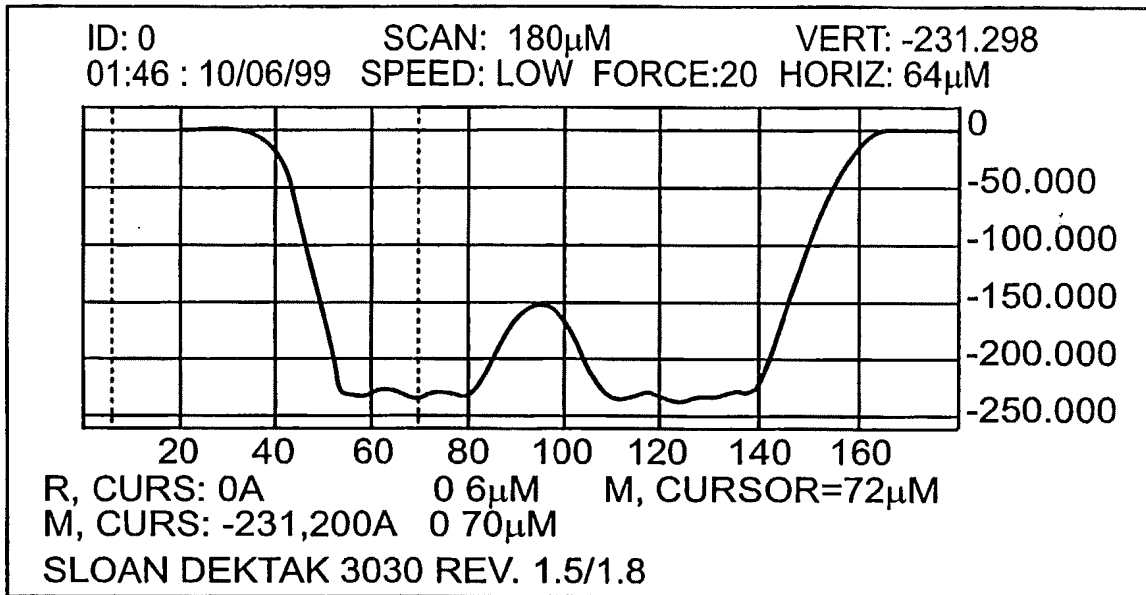

SURFACE TOPOGRAPHY SCANS FOR THE ANNULI OF FIG. 10

FIG. 12a

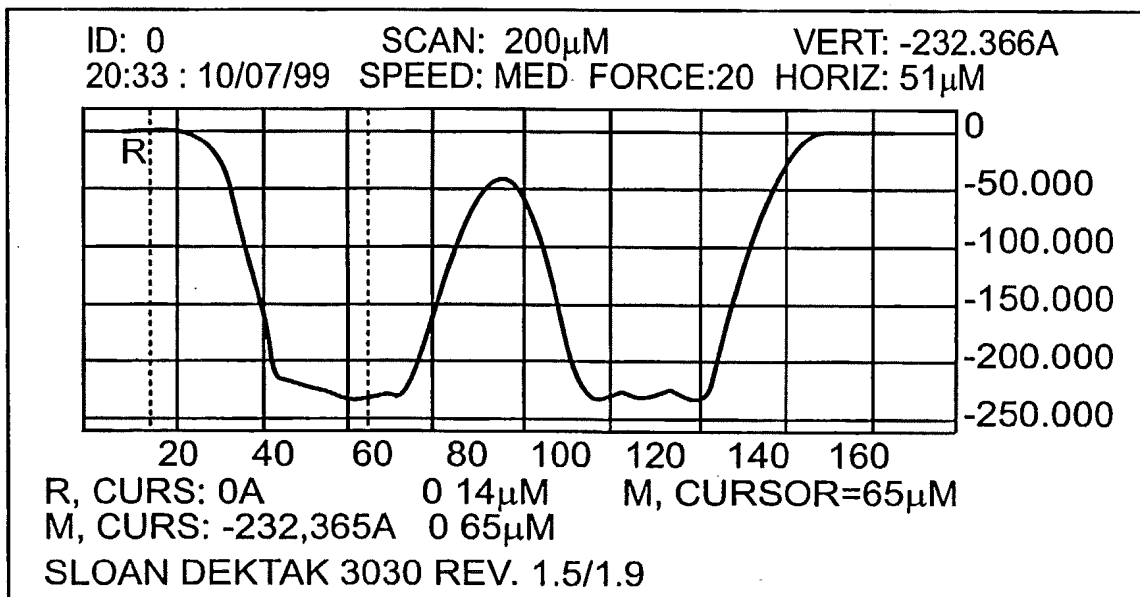

SURFACE TOPOGRAPHY SCANS FOR THE ANNULI OF FIG. 11

FIG. 12b

SUBSTITUTE SHEET (RULE 26)

10/15

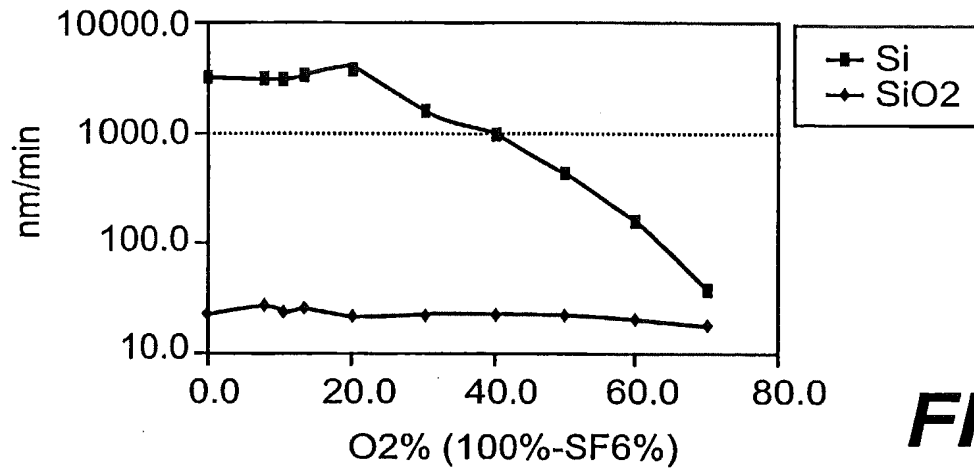

FIG. 13a

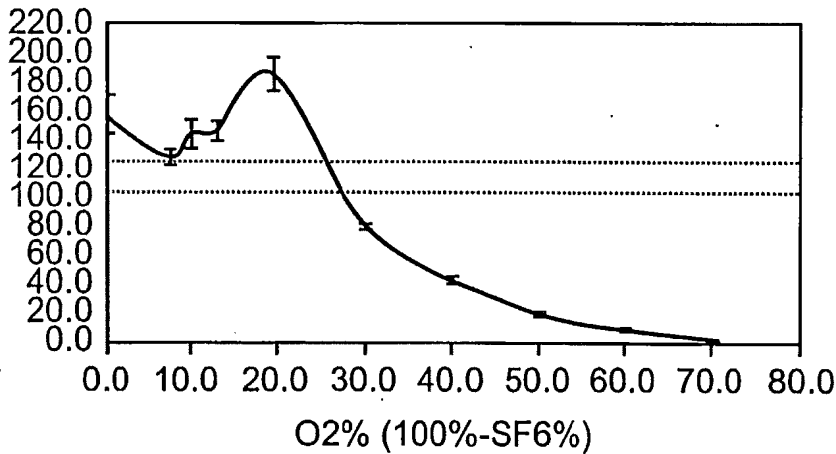

FIG. 13b

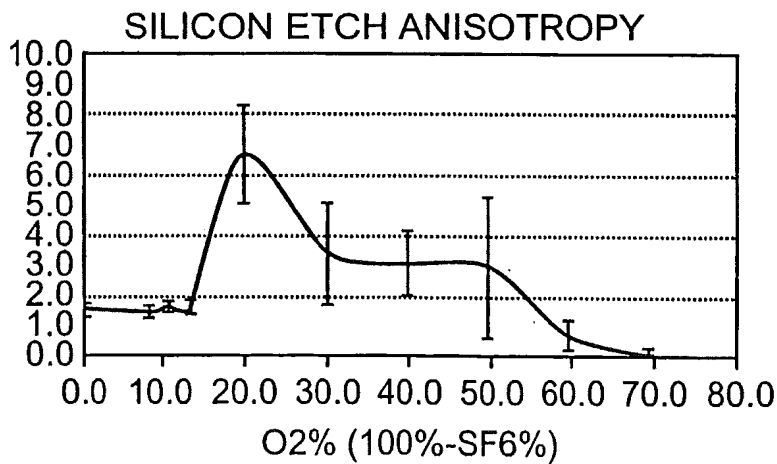

FIG. 13c

11/15

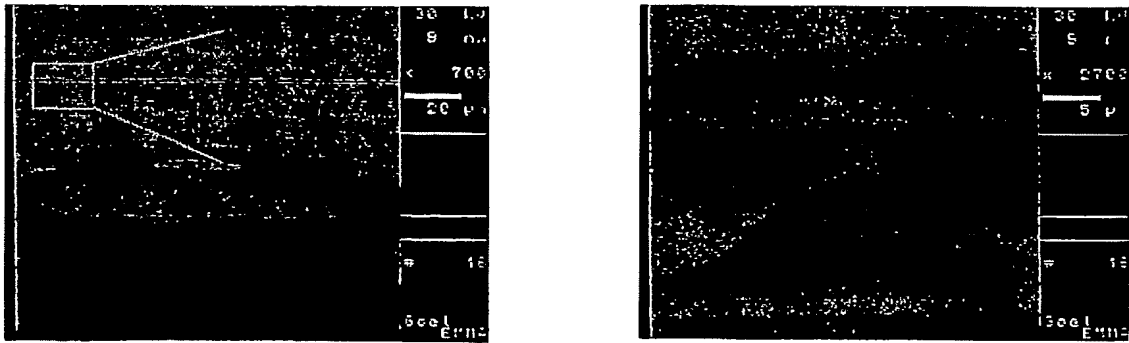

FIG. 14a

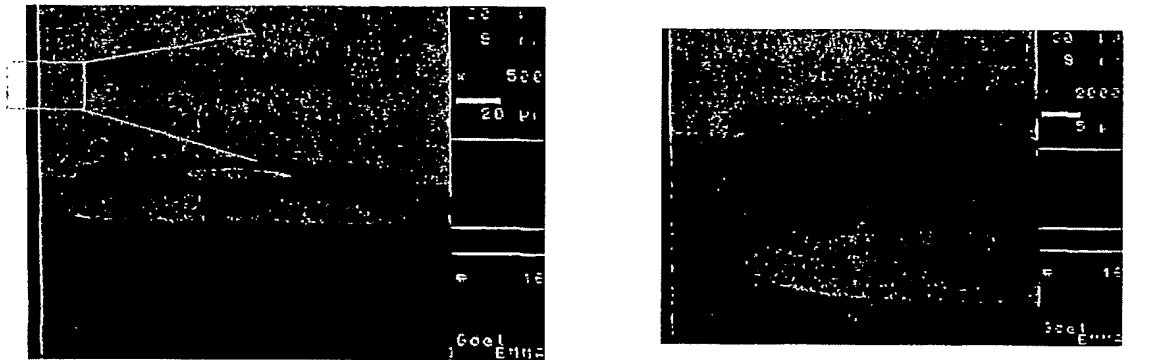

FIG. 14b

12/15

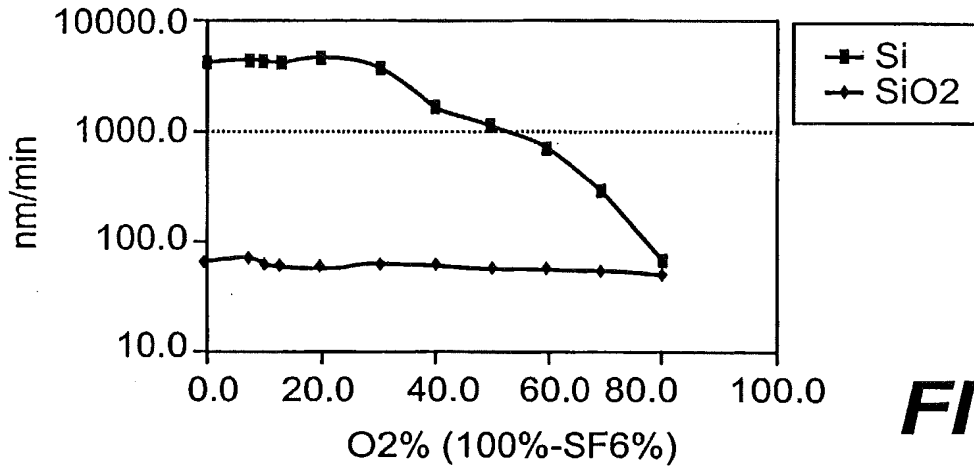

FIG. 15a

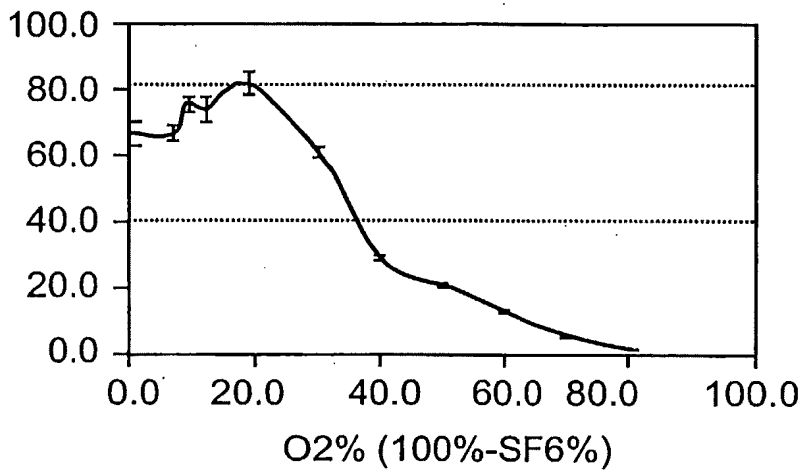

FIG. 15b

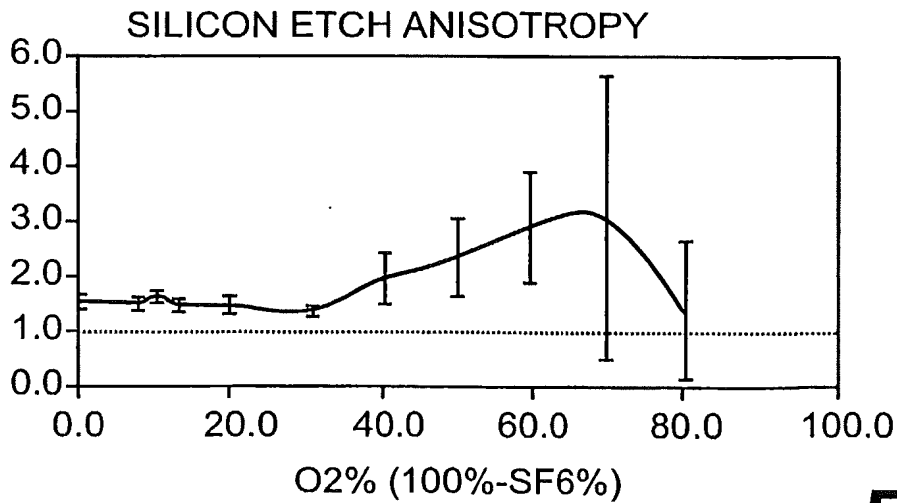

FIG. 15c

13/15

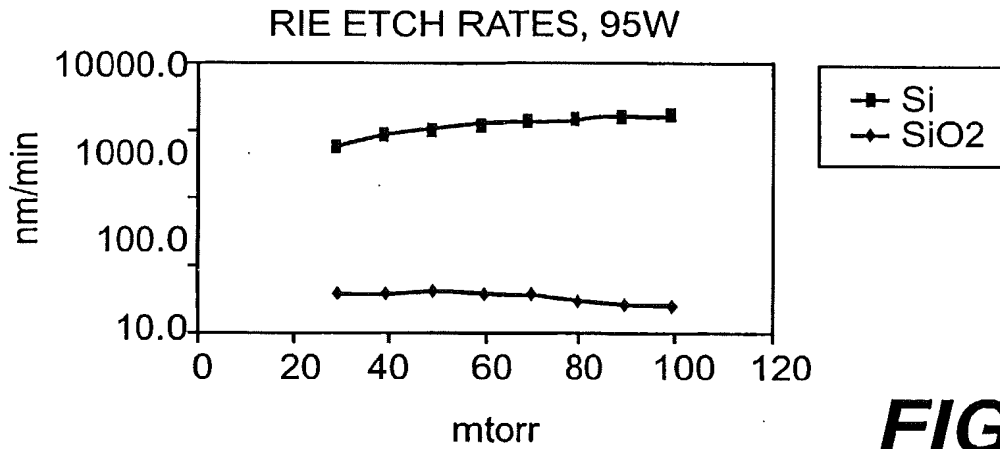

FIG. 16a

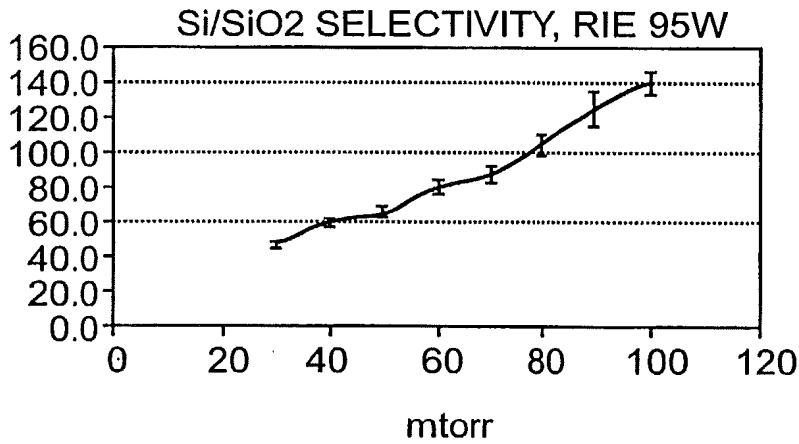

FIG. 16b

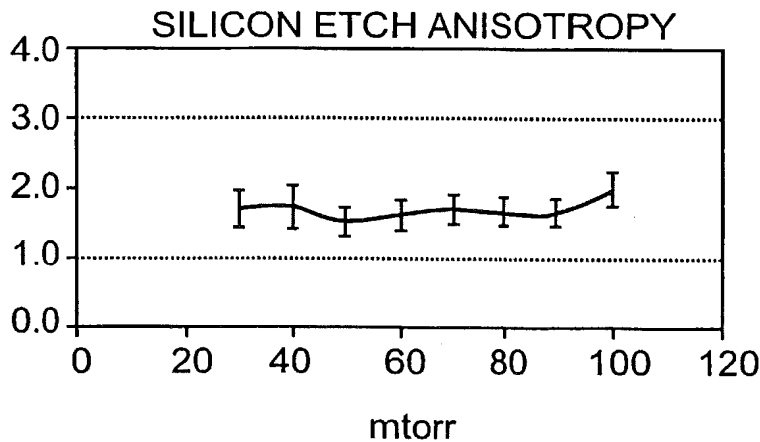
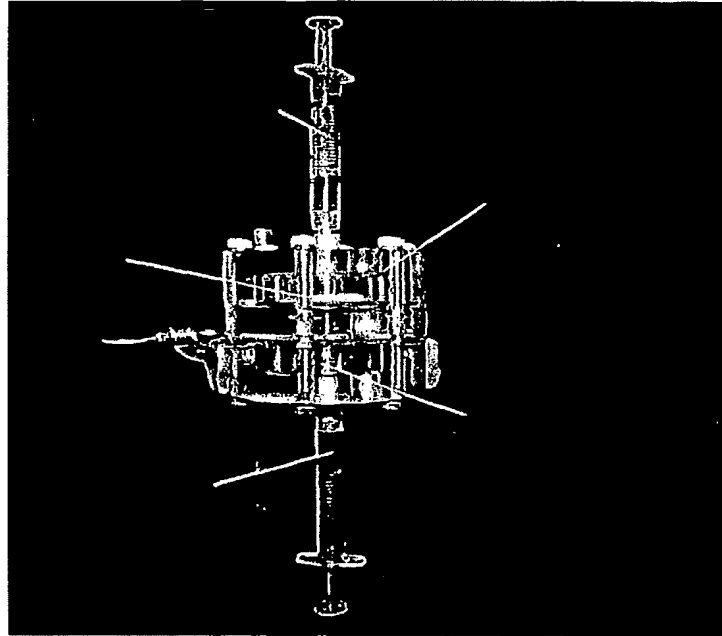

FIG. 16c

14/15



PLEXIGLAS, WATER-TIGHT CTM MACRO-MODEL FOR PRESSURE ANALYSIS

FIG. 17

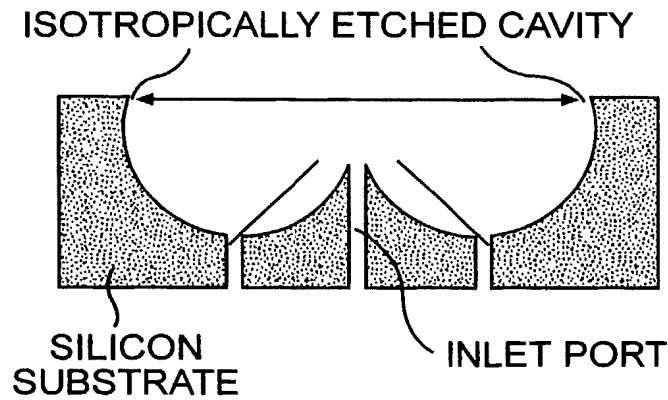

CROSS-SECTION OF THE μ -INJECTOR SHOWING INLET AND ADDED VENTING PORTS

FIG. 18

15/15

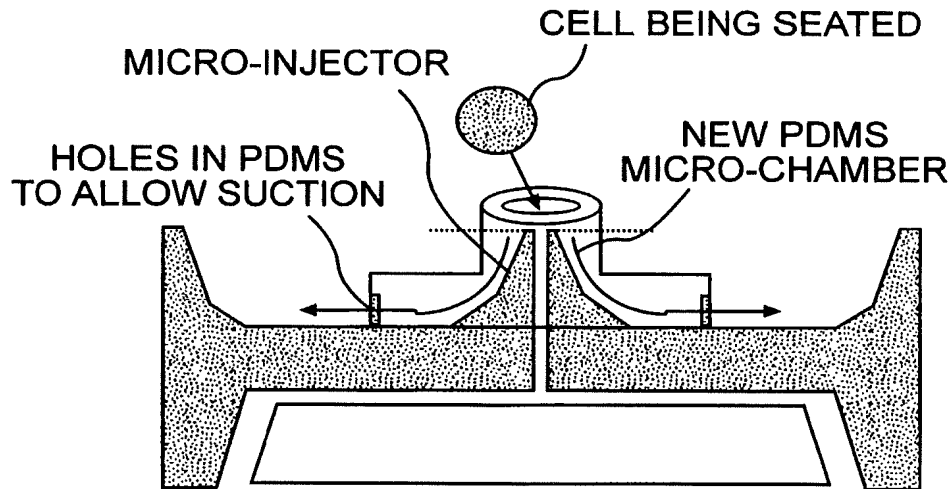

NEW DESIGN THAT USES A TOP PDMS LAYER, FORMING THE μ -CHAMBER AND ALLOWING FOR FLUID VENTING AND SUCTION. THE BOTTOM PDMS ACTS AS CAVITY BACKFILL.

FIG. 19



EM'S OF SU-8 MOLD (LEFT) AND THE RESULTING PDMS (RIGHT). THE CENTER POST IS 10 μ m IN DIAMETER.

FIG. 20

INTERNATIONAL SEARCH REPORT

Int Application No
PCT/US 01/44289A. CLASSIFICATION OF SUBJECT MATTER
IPC 7 C12M3/00

According to International Patent Classification (IPC) or to both national classification and IPC

B. FIELDS SEARCHED

Minimum documentation searched (classification system followed by classification symbols)
IPC 7 C12M

Documentation searched other than minimum documentation to the extent that such documents are included in the fields searched

Electronic data base consulted during the international search (name of data base and, where practical, search terms used)

EPO-Internal, WPI Data, PAJ

C. DOCUMENTS CONSIDERED TO BE RELEVANT

Category *	Citation of document, with indication, where appropriate, of the relevant passages	Relevant to claim No.
P, X	WO 01 19978 A (CORNELL RES FOUNDATION INC) 22 March 2001 (2001-03-22) claims; figures 3-5 ----	1-16, 18-20, 22-38, 41
X	WO 00 20554 A (SHAW JOHN EDWARD ANDREW ;BRENNAN DAVID (GB); DODGSON JOHN (GB); ZE) 13 April 2000 (2000-04-13) claims; figures ----	41-48, 50
A	US 5 183 744 A (KAWAMURA YOSHIO ET AL) 2 February 1993 (1993-02-02) ----	
A	DE 198 41 337 C (MICRONAS INTERMETALL GMBH) 23 September 1999 (1999-09-23) ----	
A	US 5 262 128 A (BROWNSTEIN MICHAEL J ET AL) 16 November 1993 (1993-11-16) ----	
	-/--	

 Further documents are listed in the continuation of box C. Patent family members are listed in annex.

* Special categories of cited documents :

- *A* document defining the general state of the art which is not considered to be of particular relevance
- *E* earlier document but published on or after the international filing date
- *L* document which may throw doubts on priority claim(s) or which is cited to establish the publication date of another citation or other special reason (as specified)
- *O* document referring to an oral disclosure, use, exhibition or other means
- *P* document published prior to the international filing date but later than the priority date claimed

- *T* later document published after the international filing date or priority date and not in conflict with the application but cited to understand the principle or theory underlying the invention
- *X* document of particular relevance; the claimed invention cannot be considered novel or cannot be considered to involve an inventive step when the document is taken alone
- *Y* document of particular relevance; the claimed invention cannot be considered to involve an inventive step when the document is combined with one or more other such documents, such combination being obvious to a person skilled in the art.
- *&* document member of the same patent family

Date of the actual completion of the international search

5 August 2002

Date of mailing of the international search report

13/08/2002

Name and mailing address of the ISA

European Patent Office, P.B. 5818 Patentlaan 2
NL - 2280 HV Rijswijk
Tel. (+31-70) 340-2040, Tx. 31 651 epo nl,
Fax: (+31-70) 340-3016

Authorized officer

Coucke, A

INTERNATIONAL SEARCH REPORT

International Application No
PCT/US 01/44289

C.(Continuation) DOCUMENTS CONSIDERED TO BE RELEVANT

Category °	Citation of document, with indication, where appropriate, of the relevant passages	Relevant to claim No.
X	<p>CHUN K ET AL: "An array of hollow microcapillaries for the controlled injection of genetic materials into animal/plant cells" MICRO ELECTRO MECHANICAL SYSTEMS, 1999. MEMS '99. TWELFTH IEEE INTERNATIONAL CONFERENCE ON ORLANDO, FL, USA 17-21 JAN. 1999, PISCATAWAY, NJ, USA, IEEE, US, 17 January 1999 (1999-01-17), pages 406-411, XP010321695 ISBN: 0-7803-5194-0 page 407</p> <p style="text-align: center;">-----</p>	41-45

INTERNATIONAL SEARCH REPORT

Information on patent family members

International Application No

PCT/US 01/44289

Patent document cited in search report		Publication date		Patent family member(s)	Publication date
WO 0119978	A	22-03-2001	AU	7578900 A	17-04-2001
			WO	0119978 A1	22-03-2001
			US	6383813 B1	07-05-2002

WO 0020554	A	13-04-2000	AU	6216199 A	26-04-2000
			EP	1124939 A1	22-08-2001
			WO	0020554 A1	13-04-2000

US 5183744	A	02-02-1993	JP	2117380 A	01-05-1990
			JP	2747304 B2	06-05-1998
			JP	2131569 A	21-05-1990
			JP	2829005 B2	25-11-1998

DE 19841337	C	23-09-1999	DE	19841337 C1	23-09-1999
			EP	0962524 A1	08-12-1999
			JP	11346764 A	21-12-1999
			DE	19827957 A1	09-12-1999
			EP	0960933 A1	01-12-1999
			JP	11346794 A	21-12-1999
			US	6368851 B1	09-04-2002

US 5262128	A	16-11-1993	AU	6640190 A	16-05-1991
			EP	0497885 A1	12-08-1992
			WO	9105519 A1	02-05-1991
